



GODFREY LOWELL CABOT SCIENCE LIBRARY  
*of the Harvard College Library*

This book is  
**FRAGILE**

and circulates only with permission.

Please handle with care  
and consult a staff member  
before photocopying.

Thanks for your help in preserving  
Harvard's library collections.

A  
TISE ON HILLS  
OLSON ALLEN  
OVIDENCE R.I.

Eng 1738.78



*The Gift of  
the Nicholson  
File Co.,  
Providence, R.I.*

*18 July, 1878*

---

This is a reproduction of a library book that was digitized by Google as part of an ongoing effort to preserve the information in books and make it universally accessible.

Google™ books

<https://books.google.com>

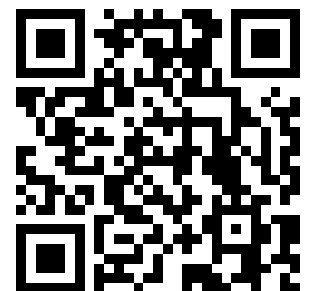





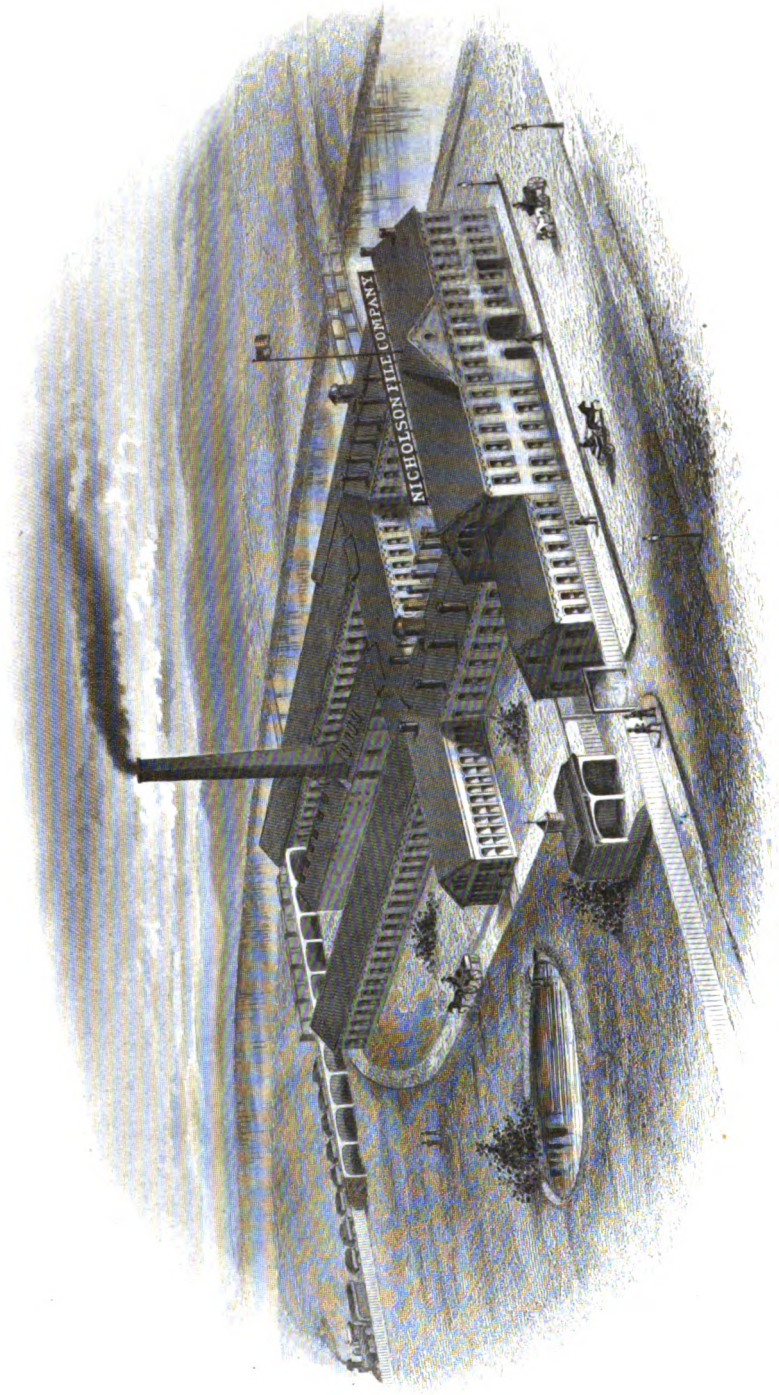

0

A TREATISE

HINTS AND REASONS

DESCRIPTIVE AND ILLUSTRATED:

FOR THE USE OF

MASTER MECHANICS, DEALERS, &C.

IN WHICH THE

KINDS OF FILES IN MOST COMMON USE, AND THE NEWEST AND MOST APPROVED SPECIAL TOOLS CONNECTED THEREWITH, ARE DESCRIBED—GIVING SOME OF THEIR PRINCIPAL USES.

WITH A DESCRIPTION

OF THE

PROCESS OF MANUFACTURE,

AND A FEW

HINTS ON THE USE AND CARE

OF THE FILE.

*E. W. T. Nicholson*

PUBLISHED BY THE

NICHOLSON FILE COMPANY,

PROVIDENCE, R. I., U. S. A.

1878.

12-2 July 18,  
copy of  
The Nicholson Case 177.  
Providence, R. I.



ENTERED ACCORDING TO ACT OF CONGRESS, IN THE YEAR 1878.

*By W. J. Nicholson,*

IN THE OFFICE OF THE LIBRARIAN OF CONGRESS, AT WASHINGTON.

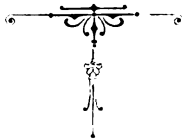

PRESS OF  
RHODE ISLAND PRINTING COMPANY,  
62 WEYBOSSET STREET,  
PROVIDENCE.





## PREFACE.

FOR several years it has been in contemplation to publish a treatise upon the several points connected with files and their uses, in which the principal, but, nevertheless, complex and confusing names and terms embodied in what are known as the Sheffield, Lancashire, and American File Lists, might be more clearly defined, and if possible, made practically intelligible, not only to the educated dealer and mechanic, but to others having less knowledge of the subject, as apprentices in machine shops, and younger clerks employed by merchants dealing in files and rasps.

After giving the subject careful consideration, as to the most desirable form in which to embody this matter *impartially*, and at the same time be able to set forth the special points of merit claimed for the goods made by the NICHOLSON FILE COMPANY, it was decided to devote so much of the work as seemed necessary, to defining clearly and concisely the general features belonging to all files, and to follow this with a detailed description of the distinguishing characteristics of the files and rasps commonly called for; giving some of the purposes for which the various kinds are used.

The aim has been to arrange the matter with as much system as possible, in order that information upon any specific point touched upon, may be readily reached when required. In accomplishing this, it was considered advisable to place under the heading of FILES SELDOM USED, all those which our experience has shown are either but little used, or are never called for, and which, if introduced into the regular text, might tend to increase somewhat the difficulty of understanding the subject.

In considering whether this matter should be illustrated by *full sized* lithographs as found in some, of both the English and American file makers' lists, we were met by the necessarily inconvenient size of the book, if to be used as a work of ready reference. We therefore decided to limit the work to its present quarto size, and make the illustrations conform to the space we have allotted them, which, we trust, will be found sufficient to furnish all the aid which the reader may require.

As to the matter introduced under the general headings of OUR SPECIALTIES, MANUFACTURE OF FILES, and HINTS ON FILING, no apology need be offered for the references made to the goods manufactured by the NICHOLSON FILE COMPANY, as, without this privilege, it is evident to the writer, this work would not have been issued. It is believed, however, that the points considered have been well taken, and that the general information will well repay most mechanics for their time.

The NICHOLSON FILE COMPANY has now been in existence for upwards of fourteen years, during which time they have permanently introduced their goods into every section of this, and to some extent into other countries, against the strongest possible prejudice in favor of hand made files; their product being now double that of the entire imports of foreign files into this country.

The plant of the Company is now, without doubt, the most complete, for the purpose, of any in the world; and no proper expenditure of money is withheld, by its managers, in their endeavors to perfect and introduce any new and useful feature bearing upon their business.

The very latest, and perhaps at no distant day, to be an important element in the manufacture of files, is now being experimented upon by this Company, and its value to files in general, determined. It consists in a patent process of impinging upon the teeth of finished files, a gritty liquid, in such a manner as shall whet the teeth to a degree of sharpness never before attainable. The advantages, when applied to Horse, Wood, Cabinet and Shoe Rasps, or upon Files for wood, brass, bronze, or other soft material, it is believed will be readily apparent to the mechanic. The benefits to be derived from a general application of the process to all files, will be determined by further experiments, and by the aid of the public.

The restless activity of the managers of this Company is evidenced by its numerous patents, found in the archives of the United States Patent Office; and its success is due to that "eternal vigilance," which adopts for its motto "*Labor Omnia Vincit*," and which, in the future—as in the past—it is believed, will characterize the management of its affairs.

W. T. N.

PROVIDENCE, *June*, 1878.



# CONTENTS

GENERAL DESCRIPTION OF FILES, . . . . .	Pages 3 to 8
DETAILED DESCRIPTION OF FILES, . . . . .	“ 9 to 24
OUR SPECIALTIES, . . . . .	“ 25 to 44
MANUFACTURE OF FILES, . . . . .	“ 45 to 62
HINTS ON FILING, . . . . .	“ 63 to 75
TERMS DEFINED, . . . . .	“ 76
FILES SELDOM USED, . . . . .	“ x. to xi.

## PLATES.

VIEW OF WORKS, . . . . .	Frontispiece.
GROUPING OF FILES, . . . . .	Page 1
QUADRANGULAR SECTIONS, . . . . .	<b>Plate A,</b> Opposite “ 10
SINGLE CUT, (Grades of Coarseness) . . . . .	<b>Plate B,</b> “ “ 14
DOUBLE CUT, (Grades of Coarseness) . . . . .	<b>Plate C,</b> “ “ 16
CIRCULAR, TRIANGULAR AND MISCELLANEOUS SECTIONS, . . . . .	<b>Plate D,</b> “ “ 20
RASP CUT, (Grades of Coarseness) . . . . .	<b>Plate E,</b> “ “ 22



# INDEX

Annealing, . . . . .	48	Double Cut described, (Plate O)	6
Back, (See Terms Defined)	76	Double Ender, . . . . .	32
Bandsaw Files, . . . . .	21	Double Half-Round Files, (See Cross Files)	23
Bastard Cut, . . . . .	6	Drawfiling, . . . . .	71
Bellied, (See Terms Defined)	76	Drill Files, (See Warding Round Edge)	14
Bent Riffers—Handled, . . . . .	34	Entering Files, (See Files Seldom Used)	
Beveled Edge Rasps, . . . . .	15	Equaling, (a shape) . . . . .	5
Blanks, File . . . . .	46	Equaling Files, (See Files Seldom Used)	
Blunt (a shape), . . . . .	5	Files, Bandsaw . . . . .	21
Boot Heel File, . . . . .	44	Files, Boot Heel . . . . .	44
Boxing and Packing, . . . . .	61	Files, Brass . . . . .	28, 29
Brass Files, . . . . .	28, 29	Files, Cabinet . . . . .	18
Bread Rasp, . . . . .	37	Files, Cant . . . . .	21
Brush, File . . . . .	38	Files, Cotter Taper . . . . .	13
Butchers' Steels, Improved . . . . .	43	Files, Cotter Equaling . . . . .	13
Cabinet Files and Rasps, . . . . .	18	Files, Cross or Crossing . . . . .	23
Cant Files, . . . . .	21	Files, Doctor . . . . .	41
Card, File . . . . .	38	Files, Drill (See Warding Round Edge)	14
Care in Putting Away, . . . . .	75	Files, Feather Edge . . . . .	23
Carrying the File, . . . . .	70	Files, Finishing . . . . .	30
Cleaning the File, . . . . .	73	Files, Flat . . . . .	11
Coarse Cut, . . . . .	6	Files, Flat Equaling . . . . .	11
Convexity in Files, . . . . .	64	Files, Flat Wood (See Files Seldom Used)	
Cotter Taper File, . . . . .	13	Files, Gang-Edger . . . . .	44
Cotter Equaling File, . . . . .	13	Files, Ginsaw . . . . .	22
Cross Files, (Crossing or Dbl. Half-Round)	23	Files, Gulleting . . . . .	16
Curry Comb Files, (See Feather Edge)	23	Files, Half-Round . . . . .	17
Cut described, . . . . .	6	Files, Half-Round Wood . . . . .	17
Cut, Single, described, (Plate B)	6	Files, Hand . . . . .	12
Cut, Double, described, (Plate O)	6	Files, Hand Equaling . . . . .	12
Cut, Rasp, described, (Plate E)	7	Files, Handsaw Blunt . . . . .	21
Cutting, . . . . .	49	Files, Handsaw, (Double Ender)	32
Teeth of Files, . . . . .	49	Files, Handsaw Taper, Single Cut,	19
Hand Cutting, . . . . .	54	Files, Handsaw Taper, Double Cut,	20
Machine Cutting, . . . . .	55	Files, Handsaw Taper, Slim . . . . .	31
Increment Cut File, . . . . .	56	Files, High Back . . . . .	18
Deductions, . . . . .	58	Files, Hook-Tooth . . . . .	18
Dead Smooth Cut, . . . . .	6	Files, Knife . . . . .	22
Devices for Holding Files, . . . . .	66	Files, Knife Blunt . . . . .	22
Doctor File, . . . . .	41	Files, Lead Float . . . . .	27

- |   |            |   |            |
|---|------------|---|------------|
| Files, Lightning . . . . .  | 22         | Gang-Edger File, . . . . .                                  | 44         |
| Files, Machine Mill . . . . .   | 41         | Ginsaw Files, . . . . .                                     | 22         |
| Files, Mill . . . . .   | 10         | Grasping the File, . . . . .                                | 69         |
| Files, Mill Blunt . . . . .   | 10         | Grinding, . . . . .   | 48         |
| Files, Mill Pointing, or Pointing, <small>(See Files Seldom Used)</small> |            | Gulleting File, . . . . .                                   | 16         |
| Files, Pillar . . . . .   | 12         | Half-Round Files, . . . . .                                 | 17         |
| Files, Pitsaw . . . . .   | 18         | Half-Round and Flat File-Rasp, . . . . .                    | 44         |
| Files, Reaper . . . . .   | 24         | Half-Round Wood File, . . . . .                             | 17         |
| Files, Roller . . . . .   | 35         | Half-Round Wood Rasps, . . . . .                            | 17         |
| Files, Round . . . . .  | 16         | Half-Round Shoe Rasp, . . . . .                             | 23         |
| Files, Round Blunt . . . . .  | 16         | Hand Cutting, . . . . .                                     | 54         |
| Files, Slotting . . . . .   | 13         | Hand File, . . . . .  | 12         |
| Files, Slim Handsaw Taper . . . . .                                       | 31         | Hand Equaling File, . . . . .                               | 12         |
| Files, Square . . . . .   | 13         | Handsaw Blunt, . . . . .                                    | 21         |
| Files, Square Blunt . . . . .   | 13         | Handsaw File, (Double Ender) . . . . .                      | 32         |
| Files, Square Equaling . . . . .  | 14         | Handsaw Taper, Single Cut, . . . . .                        | 19         |
| Files, Stub, and Holder—Detachable, . . . . .                             | 42         | Handsaw Taper, Double Cut, . . . . .                        | 20         |
| Files, Three-Square . . . . .   | 19         | Handsaw Taper, Slim . . . . .                               | 31         |
| Files, Three-Square Blunt . . . . .                                       | 19         | Hardening, . . . . .  | 58         |
| Files, Tumbler . . . . .  | 24         | Heel, . . . . .   | 4          |
| Files, Warding . . . . .  | 14         | Height of Work, . . . . .                                   | 68         |
| Files, Warding Blunt . . . . .  | 10, 14     | High Back Files, . . . . .                                  | 18         |
| Files, Warding Round Edge, or Drill, . . . . .                            | 14         | Holding Files, Devices for . . . . .                        | 40, 42, 66 |
| File-Rasps, Flat and Half-Round . . . . .                                 | 44         | Hook-Tooth File, . . . . .                                  | 18         |
| Files Seldom Used, . . . . .  | x., xi.    | Hopped, (See Terms Defined) . . . . .                       | 76         |
| File Blanks, . . . . .  | 46         | Horse Rasp, . . . . .                                       | 15         |
| File Cleaners, . . . . .  | 38         | Horse Rasp, Improved—"Racer," . . . . .                     | 26         |
| File Holders, . . . . .   | 40, 42, 66 | Increment Cut File, . . . . .                               | 56         |
| Files, Convexity in . . . . .   | 64         | Inspecting and Testing, . . . . .                           | 60         |
| Files, Cut of . . . . .   | 6          | Jig Rasp, . . . . .   | 39         |
| Files, Kind of . . . . .  | 4          | Kind or Name, . . . . .                                     | 4          |
| Files, Length of . . . . .  | 4          | Kinds, Abbreviations in Ordering . . . . .                  | 8          |
| Files Properly Handled, . . . . .   | 65         | Kit Files, . . . . . <small>(See Files Seldom Used)</small> |            |
| Filing Block, (See Terms Defined) . . . . .                               | 76         | Knife Files, . . . . .                                      | 22         |
| Filing Brass, . . . . .   | 28, 29     | Knife Blunt Files, . . . . .                                | 22         |
| Filing, Severe Test in . . . . .  | 63         | Lead Float File, . . . . .                                  | 27         |
| Finishing File, . . . . .   | 30         | Length, . . . . .   | 4          |
| First Use of a File, . . . . .  | 71         | Lightning Files, . . . . .                                  | 22         |
| Flat Files, . . . . .   | 11         | Machine Cutting, . . . . .                                  | 55         |
| Flat Equaling Files, . . . . .  | 11         | Machine Mill File, . . . . .                                | 41         |
| Flat and Half-Round File-Rasps, . . . . .                                 | 44         | Machinists' Scrapers, . . . . .                             | 36         |
| Flat Shoe Rasps, . . . . .  | 12         | Middle Cut, (See Terms Defined) . . . . .                   | 76         |
| Flat Wood File, <small>(See Files Seldom Used)</small>                    |            | Mill Files, . . . . .                                       | 10         |
| Flat Wood Rasp, . . . . .   | 11         | Mill Blunt Files, . . . . .                                 | 10, 14     |
| Float, (See Terms Defined) . . . . .                                      | 76         |   |            |
| Forging, . . . . .  | 46         |   |            |
| Frame Saw File, (see Pitsaw) . . . . .                                    | 18         |   |            |

Name or Kind, . . . . .	4	Scraping, (See Terms Defined) . . . . .	76
New Cut, (See Finishing File) . . . . .	30	Second Cut, . . . . .	6
Nicking, or Marking Files, <small>(See Files Seldom Used)</small> . . . . .		Sections, Quadrangular (Plate A) 5, 10	
Oil may be used, When . . . . .	73	Sections, Circular (Plate D) 5, 16	
Oil should not be used, When . . . . .	73	Sections, Triangular (Plate D) 5, 19	
Oval Shoe Rasps, . . . . .	24	Sections, Miscellaneous (Plate D) . . . . .	23
Over-Cut, . . . . .	6	Set, (See Terms Defined) . . . . .	76
Packing and Boxing, . . . . .	61	Shapes and Sizes, Cross-Sectional <small>(See Plates A and D)</small>	
Pickling the Work, . . . . .	72	Single Cut described, (Plate B) . . . . .	6
Pillar Files, . . . . .	12	Slim Handsaw Taper Files, . . . . .	31
Pitsaw File, . . . . .	18	Slotting File, . . . . .	13
Plain Rasp, . . . . .	15	Smooth Cut, . . . . .	6
Point, . . . . .	4	Square Files, . . . . .	13
Preparing Work, . . . . .	72	Square Blunt Files, . . . . .	13
Racer Rasp, . . . . .	26	Square Equaling Files, . . . . .	14
Rasp Cut described, (Plate E) . . . . .	7	Steels, Butchers', Patent and Regular, . . . . .	43
Rasp, Baker's (See Bread Rasp)		Steel, . . . . .	45
Rasp, Beveled Edge . . . . .	15	Steel, (See Terms Defined) . . . . .	76
Rasp, Bread . . . . .	37	Stripping or Stripped, . . . . .	49
Rasp, Cabinet . . . . .	18	Stub Files and Holder—Detachable, . . . . .	42
Rasp, File—Flat and Half-Round, . . . . .	44	Superfine or Super Cut, <small>(See Terms Defined)</small> . . . . .	76
Rasp, Flat Shoe . . . . .	12	Surface File Holder, . . . . .	40
Rasp, Flat Wood . . . . .	11	Surface Plate or Planometer, <small>(See Terms Defined)</small> . . . . .	76
Rasp, Half-Round Shoe . . . . .	23	Tangs, . . . . .	4, 47
Rasp, Half-Round Wood . . . . .	17	Tanged Rasp, . . . . .	15
Rasps, Horse . . . . .	15	Taper, (a shape) . . . . .	5
Rasp, Horse, Improved—"Racer," . . . . .	26	Taper, Full (a shape) . . . . .	5
Rasp, Horse Mouth (See Files Seldom Used)		Taper, (See Terms Defined) . . . . .	76
Rasp, Jig . . . . .	39	Taper Cotter, (See Cotter Taper) . . . . .	13
Rasp, Oval or French Shoe . . . . .	24	Teeth—Character and Coarseness, <small>(See Plates B, C and E)</small>	
Rasp, Plain . . . . .	15	Teeth of Files, . . . . .	49
Rasp, Tanged . . . . .	15	Testing and Inspecting, . . . . .	60
Reaper Files, . . . . .	24	Three-Square Files, . . . . .	19
Re-Cut or Re-Cutting, (See Terms Defined) . . . . .	76	Three-Square Blunt Files, . . . . .	19
Rifflers, Bent—Handled, . . . . .	34	Tumbler Files, . . . . .	24
Roller File, . . . . .	35	Union Cut, . . . . . (See Files Seldom Used)	
Rough Cut, . . . . .	6	Up-Cut, . . . . .	7
Round Files, . . . . .	16	Vise File Holder, . . . . .	40
Round Blunt Files, . . . . .	16	Warding Files, . . . . .	14
Safe Edge or Side, (See Terms Defined) . . . . .	76	Warding Blunt File, . . . . .	10, 14
Scorer, File . . . . .	38	Warding Round Edge File, . . . . .	14
Scrapers, Machinists' . . . . .	36		

See also "FILES SELDOM USED," next page.

# FILES SELDOM USED.

Under this heading, we include the names of files, which, during our experience as manufacturers, have seldom or never been called for. Many of them, we are satisfied, are obsolete, so far as the demand in this country is concerned; others, are in very limited use, and a few are simply other names for common files. Another class, is the files (mostly very small) used by watch and clock makers, dentists, &c., and which are only in exceptional cases, kept by the hardware dealers in this country.

Where the name of any file found in the list has suggested anything of general interest, a note has been added.

While it has been our aim to include in our text all files for which the demand is in any way regular, we nevertheless find that a few omissions of some of the less important have occurred. We therefore make the necessary corrections at this point.

**Angular.**  
**Arch.**  
**Arm.**

**Balance Wheel.**  
**Banking.**  
**Bar.**  
**Barrel.**  
**Barrel Hole.**  
**Bayonet.**  
**Bench.**  
**Bird Feather.**  
**Bird Tongue.**  
**Biscuspid.**  
**Bone or Button.**  
**Bow.**

**Carlet.**  
**Carrott.**  
**Cobler, or Bent Rasp.**  
**Cock Spur.**  
**Coffin.**  
**Cotton.**  
**Crank.**  
**Creasing.**  
**Cross, Balance.**  
**Curl.**  
**Cutler's.**  
**Cutting.**

**Double-Tang File.**—A file intended to be used by two persons, having a tang at each end for that purpose: more especially applied to rubbers, or other very heavy files.

**Double or Checkering File.**—Two files joined together—the edges of which are V shaped and cut, one of which projects beyond the other. They are used by gun makers, for checking or spacing off equidistant grooves, as seen on the small of the gun-stock. Two flat files, as fixed together in a handle, was patented in England by a Mr. Cooper, several years ago, and known under the name of *the Styloxynon*.

**Dove Tail.**

**Endless Screw.**

**Entering File.**—A file of quadrangular section, narrower than the *flat* and wider than the *pillar*, and tapered to quite a small point. It was considerably used in enlarging holes to be afterwards finished by other files. Occasionally called for.

**Equaling File.**—In both the Sheffield and Lancashire file lists, equaling files are mentioned—meaning, in most cases, a file having a constant width and thickness from point to tang, although they are sometimes made taper as in watch and clock equalings. The confusion arising from the terms *equaling*, *blunt* and *parallel* being often applied to mean the same file, has led us to define this term somewhat differently. See Kind, pages 4 and 5; Mill Blunt, page 10; Warding Blunt, page 14.

**Finishing Dentist.**

**Flat Dentist.**

**Flat Dentist Sabre.**

**Flat Dentist Curved.**

**Flat Wood File.**—A taper file made from the flat sections, having a coarse, double cut; the sizes range from 8 to 16 inches in length. They are in regular but limited use at the present day.



**Fork.****Found.**

**Frame Saw File.**—The *pitsaw file* is in some localities called a framesaw file. It is used to file the framesaws, which in shape resemble very nearly the pitsaws.

**Graille.****Grub.**

**Half-Thick File.**—A *rubber file*, nearly square in its section, but having one side rounded to nearly a half circle.

**Hollow Edge.****Jigger.**

**Joint File.**—A small blunt round file, used in filing the joints of hinges to snuff boxes, &c.

**Key.****Kirby.**

**Kit Files.**—An assortment of twelve very small files, sold for shoemakers' use, in repairing their tools.

**Knife Fork.****Lateral.****Lock.**

**Mill Pointing (or Pointing).**—A file in every way like the mill file described on page 10, except that it is made with a narrow point—used for filing saws.

**Molar.****Molding.****Nail.****Needle.**

**Nicking File (sometimes called Marking File).**—Is a small tapered half-round file, having the convex side cut smooth, while the flat side is left uncut. The sharp edge is used in marking off work from gauges.

**Olive.****Oval Dentist.****Oval Dial.****Parallel V.****Perforated.****Piano.****Piercing.****Pin.****Pinion.****Pivot.****Plug-Finishing.**

**Pottance File.**—Files corresponding in shape and cut to what we define as a *hand file*, are called by Lancashire makers, pottance files.

**Quannet.****Rail.**

**Rasp, Baker's.**—(See **Bread Rasp**, page 37.)

**Rasp, Horse Mouth.**—A short rasp (or file) having a long handle, used in filing down horses' teeth—in limited use.

**Rasp, Last Maker's.****Rat Tail File (or Mouse Tail).**—

Is sometimes used as a technical name for very small round taper files.

**Register.****Rockers.**

**Round Off File.**—A half-round *blunt* file, with the convex side left uncut; it was considerably used for rounding off the teeth of imperfectly cut gear wheels.

**Rubber File.**—A heavy, fish bellied file, mostly square or triangular in its cross-section, and sold by weight, which usually ranges from 5 to 20 pounds, though sometimes made much heavier and with two tangs.

**Screw Head.****Seamset.****Segment Saw.****Separating.****Sexagon.****Shouldering.****Sickle.**

**Slab File.**—The files known as *half-rounds* are sometimes miscalled slab files; the name undoubtedly arising from the similarity in their cross-sectional shape to the "slab" or outside piece sawn from a log.

**Slitting.****Slotting Pinion.****Striking.****Stump.****Swing Wheel.****Topper.****Topping.****Trimming.****Turn.**

**Union Cut Files.**—Are double cut files having a *fine over-cut*, and a quite coarse or *open up-cut*; the horizontal obliquity of the two cuts is the same as in the ordinary double cut, shown in **Plate C**. The principal peculiarity being, that any tendency to glide is always in the opposite direction to that of the ordinary double cut, owing to the open up-cut. The file should also free itself more readily from the filings.

**Valve.****Valve Bit.****Verge.****Vulcanite.**

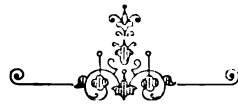

---

**“They had a File  
for the mattocks and for the colters, and for the forks and for the axes,  
and to sharpen the goads.”**

**J. Samuel, xiii. 21.**

---

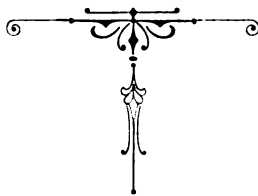

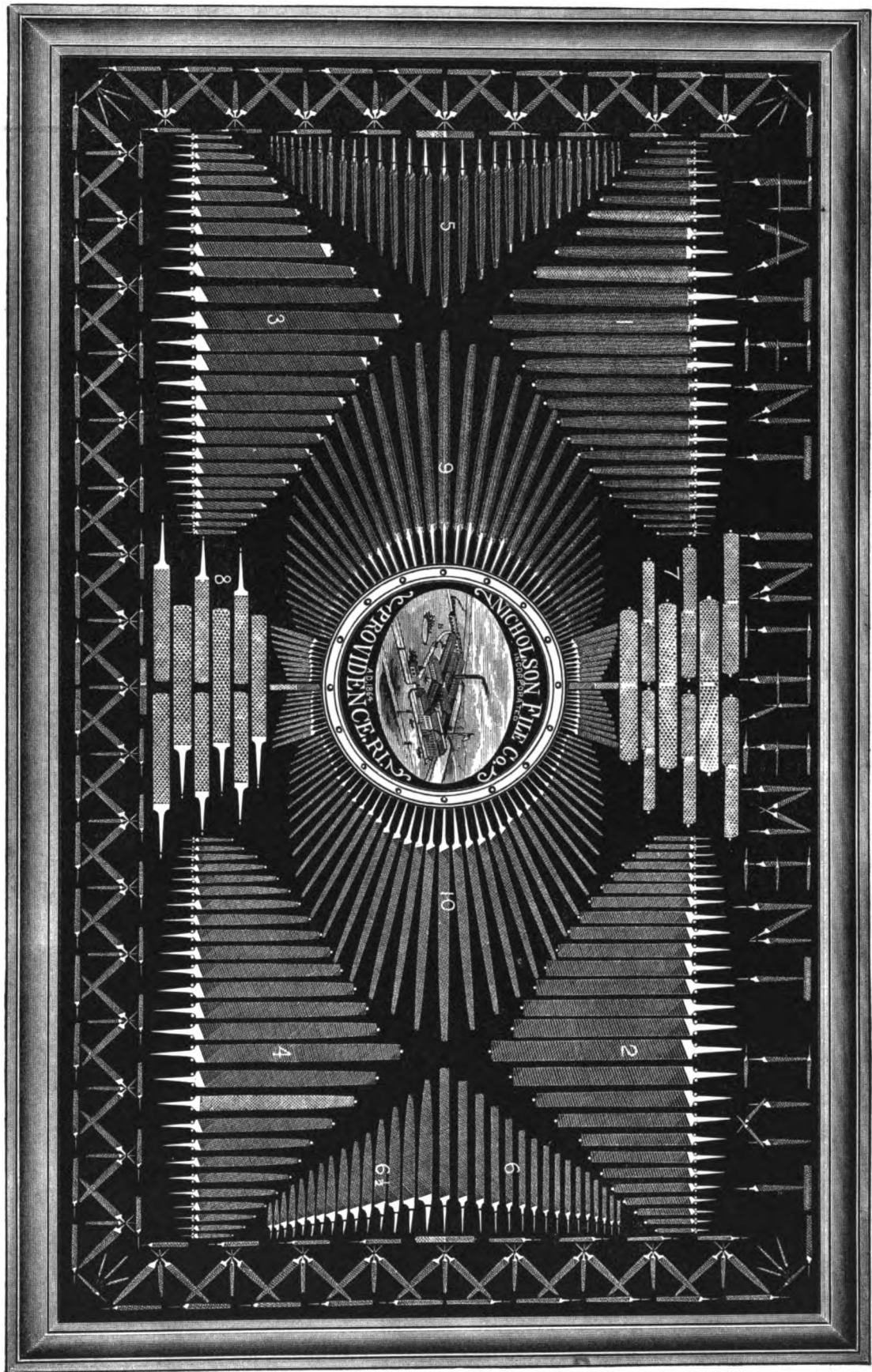

1—HALF-ROUND FILES.  
 2—HAND.  
 3—MILL.

4—FLAT.  
 5—TAPER-SQUARE.  
 6—PILLAR.

6½—KNIFE.  
 7—PLAIN RASPS.  
 8—TANGED RASPS.

9—ROUND.  
 10—SQUARE.

KNOWS AND PASSES





## GENERAL DESCRIPTION

**FILES AND RASPS** have three distinguishing features :

- 1st.* **THEIR LENGTH**—Which is always measured exclusively of their tang.
- 2d.* **THEIR KIND OR NAME**—Which has reference to the shape or style.
- 3d.* **THEIR CUT**—Which has reference not only to the *character*, but also to the relative degrees of *coarseness* of the teeth.

After giving a brief description of these features as bearing upon files in general, we shall proceed to describe the several kinds in common use, somewhat in detail.

To simplify this process, we have introduced **Plates A** and **D** to show the cross-sectional shapes and sizes of the leading kinds, and **Plates B, C** and **E** to indicate the character and fineness of the cuts or teeth. To these plates, frequent reference will be necessary.

**LENGTH.**

In general, the length of files bears no fixed proportion to either their width or thickness, even though they be of the same kind; the figures given in our illustrations of sectional shapes and sizes (**Plates A and D**) indicate, however, their lengths, as established by custom and as found in common use. In these plates, the odd inches and extreme lengths, in most cases, have been omitted, as unnecessary for the purposes of illustration.

**TANG.**—The tang is never included in the length; in the case of some few files and those of the horse and shoe rasps which are made *without tang*, the full length is given.

The term *tang* means that portion of the file which is prepared (spike shape) for the reception of a handle, and in size and shape should always be proportioned to the size of the file and to the work to be performed.

**HEEL**—Is the portion of the file to which the tang is affixed.

**POINT**—Is the end opposite to the tang, or heel.

**KIND.**

By *kind*, we mean the varied shapes or styles of files, which are distinguished by certain technical names, as for instance, *Flat, Hand, Mill, Square, Round, Pillar, Three-Square, Half-Round, &c.* A cross-section of the principal kinds may be seen in **Plates A and D**.

Some files derive their names from their transverse sectional shape, and some, from the purposes for which they are to be used, as *mills*, for filing *mill-saws*; *pitsaw* and *hook-tooth*, for filing saws designated as such; while the names of others are of doubtful or unknown origin.

To these names are added terms representing some feature of choice, as in round—*blunt*, (being distinct from the regular shape, which is *taper*;) flat—*safe-edge*; square—*equaling*; &c.

In subdividing the kinds, we find three geometrical classes, namely: those having *quadrangular* sections, as in **Plate A**, and those having *circular*, or those having *triangular* sections, as in **Plate D**.

Files made from each of these sections are the subjects of choice in their general contour or outline, usually designated as either *taper*, *blunt*, *equaling* or *parallel*. Confusion not unfrequently arises in the use of these terms; each of the three last mentioned being interpreted differently, or oftentimes used to imply the same meaning. With a view, therefore, of obviating the confusion in this work, we give below a definition of the terms used by us to describe the general *contour* or *outline* of the several kinds, which are—*Taper*, *Full Taper*, *Blunt*, and *Equaling*; dropping the term *parallel* as applied to any particular kind, using it only in its general meaning.

**TAPER**—We shall use to describe any file, the *point* of which is more or less reduced in size by a *curved taper* extending from one-half to two-thirds the length of the file, from the point.

**FULL TAPER**.—By *full taper*, we describe any file which is not only tapered (as defined by us) at the *point*, but in which a slight curvature is continued to the *heel*—its greatest cross-section being at or near the middle of the file.

**BLUNT**.—This term we apply in describing files which preserve their sectional shape throughout, from *point* to *tang*.

**EQUALING**—Is a term applied to describe a *blunt file* upon which is produced an *exceedingly* slight belly or curvature, extending from *point* to *tang*—the file *apparently* remaining blunt.

The *taper*, *full taper* and *equaling* shapes may be applied to either the sides or edges of files, or to both; though the full taper is usually applied to the sides, and is sometimes called *bellied*.

**CUT:**

Of the *Cut* of files we may say, that it consists of three distinct forms, viz.: *Single Cut*, *Double Cut*, and *Rasp*—each of which has different degrees of coarseness, designated by terms, as follows, viz.:

Rough,	Single Cut.	Coarse,	Double Cut.	Coarse,	Rasp.
Coarse,	“ “	Bastard,	“ “	Bastard,	“
Bastard,	“ “	2d Cut,	“ “	2d Cut,	“
2d Cut,	“ “	Smooth,	“ “	Smooth,	“
Smooth,	“ “	Dead Smooth,	“ “		

The terms *rough*, *coarse*, *bastard*, *2d cut*, *smooth* and *dead smooth*, have reference only to the *coarseness* of the teeth, while the terms *single cut*, *double cut* and *rasp*, have special reference to the *character* of the teeth.

**SINGLE CUT.**—The single cut files (the coarser grades of which are sometimes called *floats*.) are those in which the teeth are unbroken, the blanks having had a single course of chisel cuts across their surface, arranged parallel to each other, but with a horizontal obliquity to the central line, varying from 5 to 20 degrees in different files, according to requirements.

Its several gradations of coarseness are designated by the terms *Rough*, *Coarse*, *Bastard*, *2d Cut* and *Smooth*. (See illustrations in **Plate B.**)

The *Rough* and *Coarse* are adapted to files used upon soft metals, as lead, pewter, &c., and, to some extent, upon wood. The *Bastard* and *2d Cut* are applied principally upon files used to sharpen the thin edges of saw-teeth, which, from their nature, are very destructive to the delicate points of the double cut. The *Smooth* is seldom applied upon other than the round files, and the backs of the half-rounds.

**DOUBLE CUT.**—Files having two courses of chisel cuts crossing each other, are called *double cut*.

The first course is called the **over-cut**, and has a horizontal obliquity with the central line of the file, ranging from 35 to 55 degrees.



The second course, which crosses the first, and in most double cuts is finer, is called the **up-cut**, and has a horizontal obliquity varying from 5 to 15 degrees.

These two courses fill the surface of the file with teeth, inclining towards its point; the points of which resemble, somewhat, when magnified, those of the diamond shaped cutting tools in general use.

This form of cut is made in several gradations of coarseness, which are designated by the terms *Coarse*, *Bastard*, *2d Cut*, *Smooth* and *Dead Smooth*, the first four of which are very clearly illustrated in **Plate C**. The *Dead Smooth* is in every way like the *Smooth*, but considerably finer, and but little called for.

The *double cut* is applied to most of the files used by the machinist, and in fact to much the larger variety in general use.

**RASP CUT.**—Rasps differ from the single or double cut files, in the respect that the teeth are disconnected from each other, each tooth being made by a single pointed tool, denominated by file makers, a *punch*; the essential requirement being, that the teeth thus formed shall be so irregularly intermingled as to produce, when put to use, the smoothest possible work consistent with the number of teeth contained in the surface of the rasp.

*Rasps*, like *files*, have different degrees of coarseness, designated by us, as *Coarse*, *Bastard*, *2d Cut* and *Smooth*. The character and general coarseness of these cuts, as found in the different sizes, we have clearly set forth in **Plate E**.

Generally speaking, the *coarse* teeth are applied to rasps used by horse shoers; the *bastard*, to those used by carriage makers and wheelwrights; the *2d cut*, to shoe rasps; and the *smooth*, to the rasps used by cabinet makers.

For some special purposes, both files and rasps are cut somewhat at variance with those we have illustrated, both in respect to the angles at which the face of the teeth is presented to the work, and with reference to the teeth clearing themselves from the filings, of which, more will be said hereafter, under the heading of "Specialties."

From a review of the foregoing general description, we find in these three principal features—*Length, Kind* and *Cut*—*subdivisions*, of which, (although not always used,) six are essential in a correct description of some files; in others, five, or four, are required.

The following examples will illustrate some of these subdivisions as correctly stated; also, in italics, the manner in which they are not unfrequently abbreviated; these abbreviations being established by custom, and, while quite generally understood, cause at times much delay and annoyance by their improper use when *ordering*.

LENGTH.	KIND.			CUT.		NO. OF SUBDIVISIONS.
6 in.	Square,	Equaling,	1 Safe Side,	Smooth,	Double,	6 when correct.
10 in. }	Mill,	Taper,		2d Cut,	Single,	5 when correct.
	<i>Mill,</i>			<i>2d Cut,</i>		<i>3 when abbreviated.</i>
4 in. }	Handsaw	Taper,		2d Cut,	Single,	5 when correct.
	<i>Taper,</i>					<i>2 when abbreviated.</i>
12 in. }	Flat,	Taper,		Bastard,	Double,	5 when correct.
	<i>Flat,</i>			<i>Bastard,</i>		<i>3 when abbreviated.</i>

With this brief description, we shall proceed to a more detailed explanation of the different kinds of files and their cuts; giving some of their uses, as we have found them entering into the industries of the country; omitting, however, such files as are used by the dentist, watchmaker and the like, which branch of the business more particularly belongs to a special class of file makers.





## DETAILED DESCRIPTION

We have already stated that files are made of quadrangular, circular and triangular sections; we have, therefore, selected this geometrical order of division in our description and illustrations, and shall, before describing any of the *Specialties* manufactured by us, treat of the Files and Rasps in common use, describing first, those made of quadrangular sections.

Before proceeding with our detailed description, we should state that in most cases, files—whether they are known as single or double cut—have their edges, *single cut*, or, as is sometimes the case in the thicker files, "*hopped*;"\* the grade of coarseness being always regulated by that of the sides. Reference, therefore, will seldom be made to the cut of the edges. Where no reference is made to the contrary, it should be understood that the file being described, is cut on both its sides and edges.

\* See Hopped.

## QUADRANGULAR SECTIONS.



**MILL FILES**—Are made of the sections shown in **Plate A**. In shape they are slightly *taper*, both in their thickness and width, from the middle to the point. For some purposes they are made with *one*, and sometimes *two round edges*.

They are usually made *bastard* or *2d cut, single*, (see **Plate B**,) and cut on both their faces and edges. Occasionally they are called for, *2d cut, double*, as in **Plate C**.

*Mill files*, of both cuts, are principally used for sharpening mill-saws, from which the name—mill—is derived. They are also used to sharpen mowing-machine knives, and plows; and in machine shops, for lathe work, drawfiling, and, to some extent, in finishing the several compositions of brass and bronze.

**MILL BLUNT**.—Mill sections are occasionally made *blunt*,\* mostly *double cut*, as in **Plate C**, being seldom called for below eight inches in length; and are used principally in machine shops in working out narrow mortises. This file, together with what we describe as *Warding Blunt*, by some authorities, are named *Equaling Files*.†

*Mill blunts* are sometimes made with their edges ground to suit the particular shape of the gullet, in the teeth of the saws upon which they are intended to be used—and are cut *single*, like the ordinary mill file.

\* See Machine Mill File.

† See Kind, in General Description, page 4.

# Quadrangular Sections of Mill.

plate  
**A**

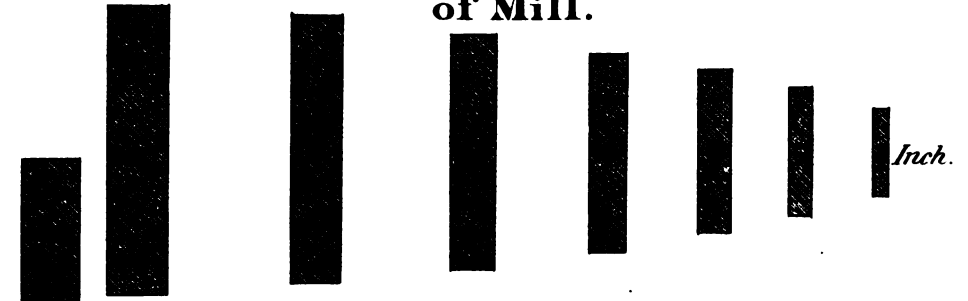

## of Flat.

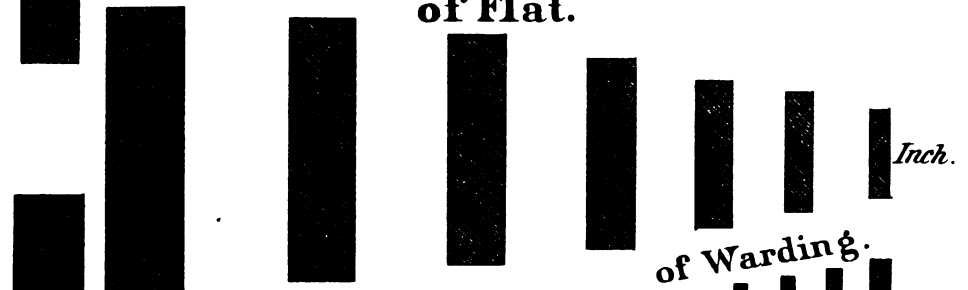

## of Warding.



## of Hand.

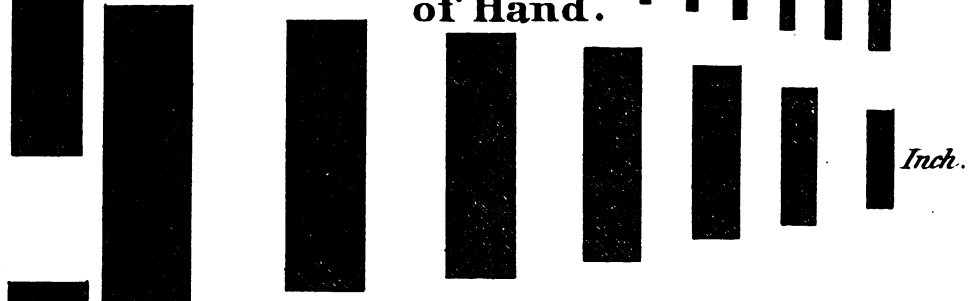

## of Pillar.

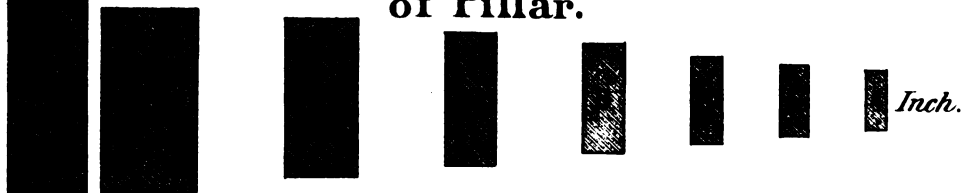

## of Square.

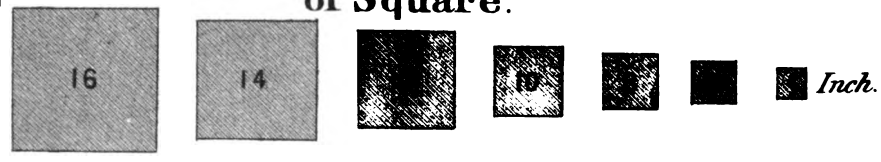





**FLAT FILES.**—While “flat files” may be considered strictly as meaning any files of rectangular section, or whose width is greater than their thickness, the file technically known as the *flat*, is of the sectional shapes shown in **Plate A**.

*Flat files*, when ten inches and under in length, are made *taper* on both their sides and edges; when longer than ten inches, they should be *full taper* on their sides at least.\*

They are usually made *double cut*, of the four varieties of teeth shown in **Plate C**, much the larger proportion being *bastard cut*.

The larger sizes are not unfrequently called for of the *coarse cut*, and are used upon leather, wood, and the softer metals.

The *flat bastard* is one of the most common files in use, and is not confined to any specific kind of work, but is employed by mechanics generally, for a great variety of purposes, in the coarser kinds of filing.

The *flat 2d cuts* and *smooths* are also in general use amongst mechanics, for finishing metals previously prepared by the *bastard*, to be followed by the *dead smooth* file, and emery processes.

**FLAT EQUALING.**—The flat sections are sometimes made *equaling* in their shape; *double cut*, principally *2d cut* or *smooth*.

They serve an excellent purpose in finishing broad mortises, as in the Pitman Heads, (used upon the larger engines,) to prepare them for the gib and key.

**FLAT WOOD RASPS**—Except in the form of their teeth, are like the *flat file*. Their sides are punched *rasp*, usually *bastard*, as in **Plate E**; their edges being cut *coarse, single*, as in **Plate B**. They are used by wheelwrights and carriage builders.

\* See Hints on Filing.

**FLAT SHOE RASPS**—Are made from the *flat* sections, but since the introduction of the *Half-Round Shoe Rasp*, they are very rarely called for. They are slightly *tapered* on their sides, at both ends, but have parallel edges.

They are cut on their sides only; usually, half, *rasp*, *2d cut*—as in **Plate E**, and the other half, *bastard*, *double cut*—as in **Plate C**, on their reverse quarters; the edges being left *safe*.

They are used by boot and shoe makers in filing and trimming the bottoms of boots and shoes.

**HAND FILE.**—While the term *hand* has a general meaning which would include most kinds of files, it is, like the term “flat,” used to designate a particular kind, whose section is like the *flat*, except that it is somewhat heavier, as may be seen by reference to **Plate A**. In form, they are *full tapered* (or bellied) on their sides, and nearly parallel in width.

They are cut *double*, of the general character shown in **Plate C**, on their sides, and have one edge cut *single*, the other edge being left *safe* or uncut. Although the *bastard* is much the most common grade of cut, *2d cut* and *smooth* are considerably used, and in the smaller sizes, *dead smooth*.

This form of file is preferred amongst machinists and engineers for finishing flat surfaces, and, owing to its having one safe edge, is particularly useful where the flat file would not answer.

**HAND EQUALING.**—The hand sections are, to some extent, made *equaling*; their cut, and the purposes for which they are used, being the same as the *flat equaling*.

**PILLAR FILES.**—The sides of pillar files are *full taper*, while the edges are nearly parallel, one of which is usually left *safe*. They resemble, in their general shape, the hand file, except that they are very much narrower. See **Plate A** for cross sections.

They are cut *double*, of any degree of fineness shown in **Plate C**.

While not in general use, they are especially adapted where any considerable quantity of narrow work is to be finished, being a useful file for some classes of gun work.



**SLOTTING FILE**—Is a file made from the *pillar* sections, **Plate A**. Its sides and edges should be made *equaling*. It is cut *double*, as in **Plate C**, and is principally useful in filing grooves for cotters, keys or wedges.

**COTTER TAPER**.—A file made from the *pillar* sections, but advancing two inches in its length on the pillar sizes, a 6 inch pillar making an 8 inch *cotter*, &c. It is made considerably *taper* on both its sides and edges, and is cut *double*.

This file is often called *taper cotter*, and, while applicable to special purposes, is seldom called for.

**COTTER EQUALING**—Is of the same section, size and cut as the *cotter taper*, but is made *equaling* in shape.

It is generally used for the same purposes as the *flat equaling* and *slotting* files, and is in limited demand.

**SQUARE FILES**.—*Square taper* files range from 3 to 16 inches in length, of the sectional sizes shown in **Plate A**, being generally made with considerable *taper*.

They are usually *double cut*, (see **Plate C**,) the *bastard* being the principal form of teeth. *2d cut* and *smooth* are occasionally called for, while the *coarse* and *dead smooth* cuts are seldom used.

The *square taper* files are very generally used in almost all branches of mechanical industry, principally, for enlarging apertures of a square or rectangular shape.

**SQUARE BLUNT**.—These files range from 10 to 20 inches in length, of the same sectional sizes as the *square tapers*, and are cut *double*, usually *bastard*. They are sometimes called for with *one*, and sometimes *two safe sides*.

They are considerably used by engine builders, and in the shops of railroads and ship-yards, for the rougher work in finishing or enlarging mortises, key-ways, or splines, when of considerable length.

**SQUARE EQUALING.**—These files are in every respect like the *square blunt*, except in the care taken to prepare a *curve* or *belly* (as implied by the term *equaling*); owing to which, they are much better adapted than the *blunt*, to the nicer work in finishing key-ways, splines, &c.

While they are principally cut *bastard*, *double*, this shape is preferable to the *blunt*, for any of the finer cuts, as *2d cut* or *smooth*.

**WARDING FILES**—Are of the sections shown in **Plate A**. They are made parallel in thickness, but considerably *tapered* on their edges, and range in size from 3 to 8 inches in length, by half inches, below 6 inch.

They are cut *double*, rather finer, but of the character of the cuts shown in **Plate C**.

*Warding* files are considerably used by jewelers and machinists; but more especially by locksmiths, in filing the ward notches in keys.

**WARDING BLUNT**—As made by us, together with our *Mill Blunt*, answer to what is laid down in English works as the *Equaling File*. Owing to the confusion which has arisen in the use of the terms *equaling*, *parallel* and *blunt*,\* we have adopted the name *Warding Blunt*; which, by most authorities, means a thin blunt file.

They are made of any of the sections of *warding* shown in **Plate A**, and are usually cut *double*, rather finer than shown in **Plate C**.

While, from their parallelism, they are adapted to specific purposes and trades, they are also considerably used for the same purposes as the *warding taper*.

**WARDING ROUND EDGE, or DRILL FILES**—Are made *blunt*, from *warding* sections, and cut upon their *edges* only, which are made quite rounding; *2d cut*, *single*, being the usual form.

This file is especially adapted to extending or rounding the bottom of slits, where the round file would be found too frail; also as a drill file, for filing small twist drills, and for other purposes of a similar nature.

\* See Kind, in General Description, page 4.

# Single Cut.

Plate

# B

Rough.

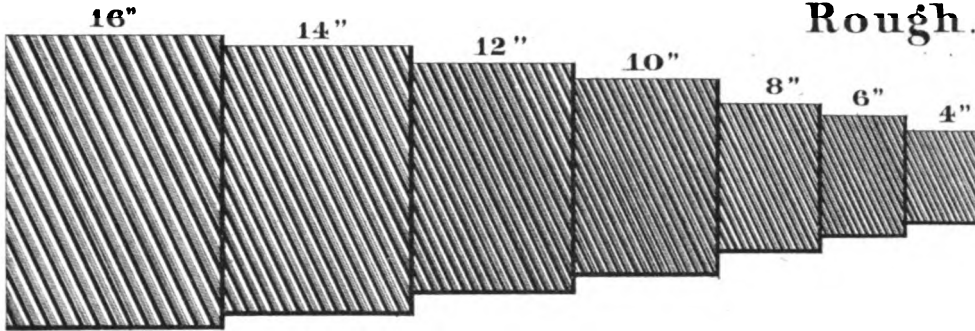

Coarse.

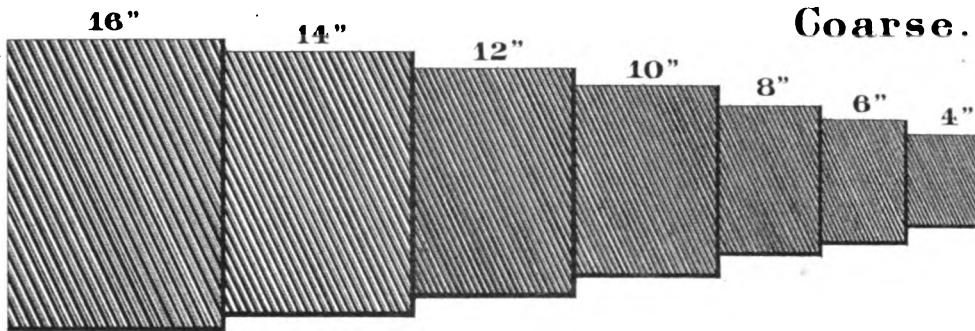

Bastard.

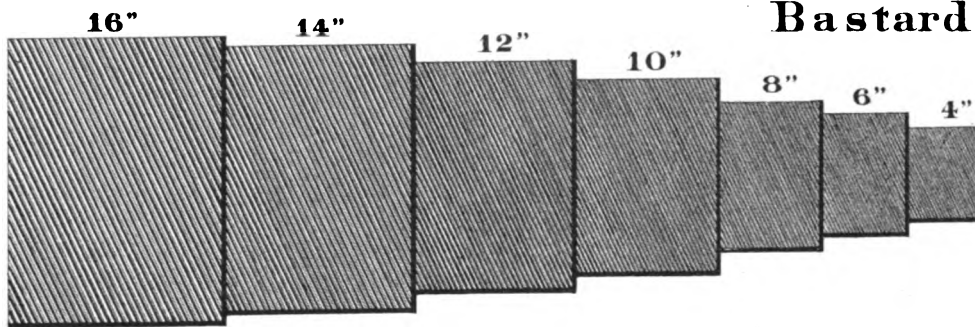

2 d Cut.

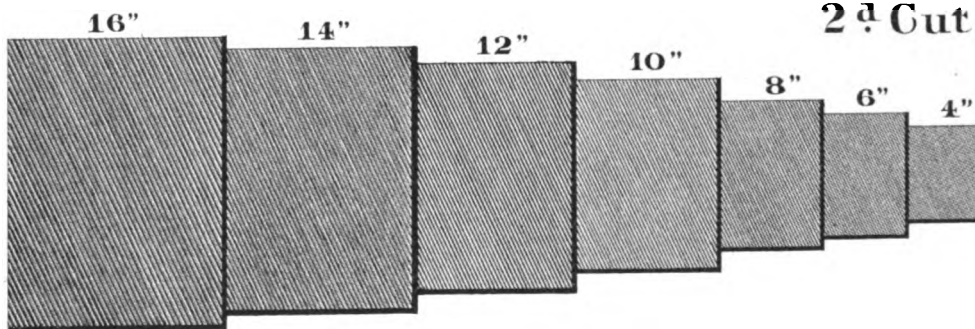





**RASPS—HORSE.**—The rasp sections in **Plate A** are rarely ever used for any other purpose than in making horse rasps, known as *Tanged*, or *Plain Rasps*.

The horse shoers of the New England, and, to some extent, of the Middle States, use the *tanged rasp*; which, in shape, is like the *hand file*, although much heavier, and is provided with a *tang* for a handle.

The *plain rasp* is used by horse and mule shoers in the Middle, Southern and Western States. In shape, as distinct from the tanged rasp, it is double ended; the ends being slightly rounded, and its sides *tapered* at both ends, while its edges are nearly parallel.

The teeth of *tanged rasps* all face in the direction of the *point*, while those of the *plain rasp* face toward each end, from the middle. Both tanged and plain rasps are made with one side *cut, coarse, double*, as in **Plate C**, and the opposite side *punched, coarse, rasp*, as in **Plate E**; their edges being usually *single cut*, sometimes *hopped*.

In the *Plain Rasps*, in some cases, half of one side is rasp, and the other half, file, being reversed on the opposite side; they are then called *Plain Rasp, 1/2 File, Reversed*. In other cases, they are required with one, and half of the opposite side, either rasp or file; in such cases, they are designated as *Plain Rasp, 3/4 Rasp*, or *File*, as the case may be.

*Plain Rasps* are required, occasionally, with the edges of one or more of their rasp quarters—beveled, in which case they are called *Beveled Edge Rasps*; and, in describing them, the terms  $\frac{1}{4}$  beveled or  $\frac{1}{2}$  beveled should be added, as follows:

*Plain Rasp, 1/2 File, Reversed, 1/4 Beveled.*  
*Plain Rasp, 3/4 File, 1/2 Beveled.*

the  $\frac{1}{4}$  beveled being the usual form required.

## CIRCULAR SECTIONS.



**ROUND FILES**—Are circular in section, as in **Plate D**, ranging from 2 to 16 inches in length, and made considerably *taper*; this shape being the one usually called for, in round files.

The small *bastards* are mostly *single cut*, as in **Plate B**, and the larger sizes, *double cut*, as in **Plate C**. The *2d cuts* and *smooths* are rarely *double cut*, except in some of the very large sizes of these files. In imitation, they are, however, sometimes made with the first or *over-cut*, very open, called *hopped*; but this, as usually applied, is considered of little value, except for looks.

The *bastard cut* is principally called for, and is used for enlarging round holes, and shaping internal angles which are filled in; for which uses the *quadrangular* sections would be unsuitable.

**ROUND BLUNT.**—For some classes of work, the *blunt* is preferred. They are of the same sectional sizes as shown in **Plate D**, and are not unfrequently called for 18 and even 20 inches in length; their principal cut being *bastard, double*.

Their use is mainly confined to the heavier work of ship-yards and railroad shops, and of engine and bridge building.

In all cases where it is possible to adapt them, the *round* files, both *taper* and *blunt*, are preferred to the so called *half-round*, of the same sectional curvature, on account of their greater strength.

**GULLETING FILE**—Is a *round blunt sawfile*, and, like most other files for this purpose, (except for a short space at the point, which is left uncut,) is cut *single*, as in **Plate B**.

Its principal use is in extending the *gullet* of the teeth of what are known as the gullet-tooth and briar-tooth saws.

# Double Cut.

Plate  
**C**

Coarse.

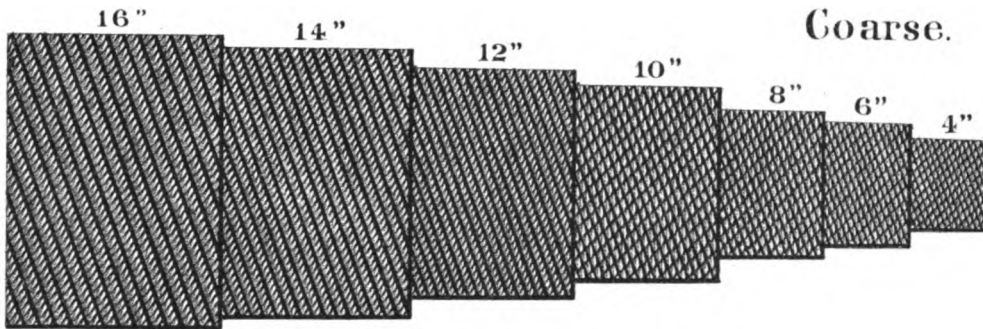

Bastard.

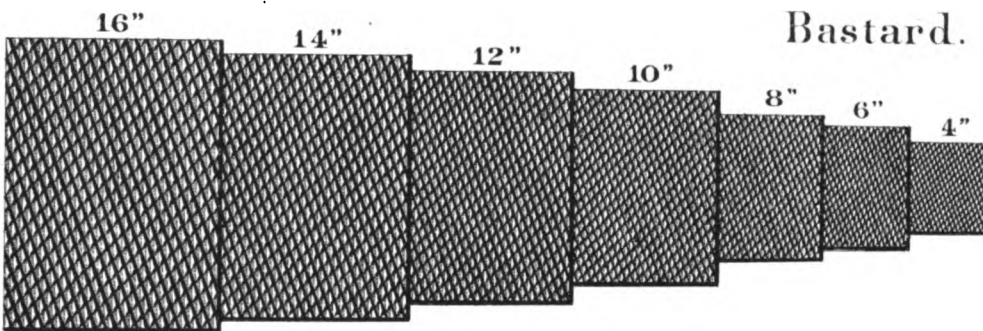

2<sup>d</sup> Cut.

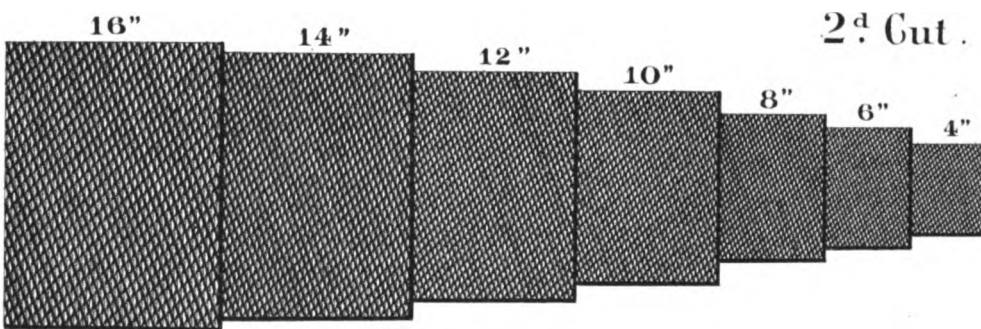

Smooth.

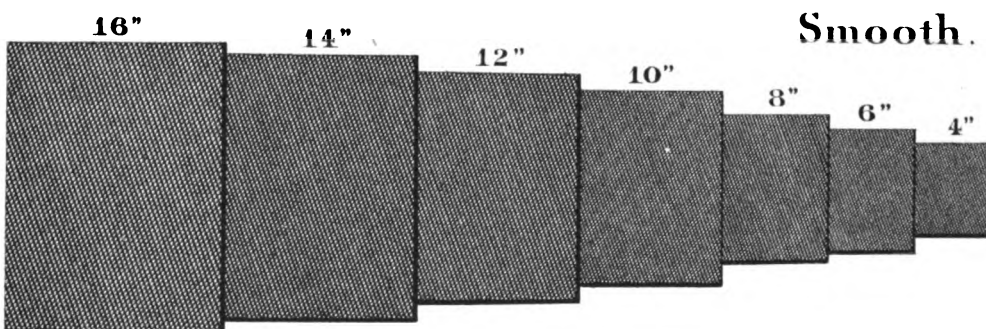





**HALF-ROUND FILES**—Are of the section shown in **Plate D**. Although the name implies a semicircle in section, as generally made, their curvature does not exceed the third part of a circle. In shape, they are made *taper*.

The *bastard* is usually *double cut*, as in **Plate C**, on both its convex and flat sides. The *2d cut* and *smooth* are cut *double* on their flat side, while the convex side is cut *single*, as in **Plate B**, except occasionally in the larger sizes, when it is either cut *double*, or *hopped*.

The *half-round bastard*, together with the *round*, *square*, and *flat bastard*, answer the large majority of the requirements of the machinist. The *2d cut* and *smooth* are used in reducing the work from the *bastard*, preparatory to the emery processes of finishing.

The convex side of the *half-round* has a wide range in its usefulness, in preparing and shaping the great variety of concave work.

The flat side is used for general purposes, the acute angle of its edges making it very useful where the flat, square, or three-square files will not enter.

**HALF-ROUND WOOD FILES**—Usually range in size from 10 to 14 inches, and are made of the *half-round* sections, and *tapered* in shape, like the regular *half-rounds*.

They are cut *coarse*, *double*, and are used by wood-workers generally, and, in some cases, upon the coarser kinds of brass work; although not so well adapted for this purpose, as the *coarse cut*, *brass file*, described among our special files.

**HALF-ROUND WOOD RASPS**—Are in every respect like the *half-round file*, in their shape; the sizes usually called for being 10, 12 and 14 inch.

The teeth are *punched*, of the coarseness of *bastard cut*, (see **Plate E**,) on both the convex and flat sides.

They are used principally by wheelwrights and carriage builders, and, though best adapted for wood work, are, to some extent, used by plumbers and marble-workers.

**HOOK-TOOTH FILE.**—A *saw* file of the *half-round* section; the sizes ranging from 6 to 12 inches in length. They are made *blunt*, and mostly cut *bastard* or *2d cut, single*, as in **Plate B**.

They are used principally in sharpening the teeth of the cross-cut saws technically called hook-tooth.

**PITSAW FILE.**—A *sawfile* of the section shown in **Plate D**, *blunt* in its shape; the sizes in most common use, being from 5 to 8 inches, inclusive. It is *single cut*, as in **Plate B**, on both its flat and convex sides, usually *2d cut*, having a short space at its point uncut.

It is used for filing the teeth of what are known as pit and frame saws, and is sometimes called a *frame saw* file.

**HIGH BACK.**—A name given to files made from sections having a greater curvature than the so-called *half-rounds*, closely resembling our *pitsaw* sections, **Plate D**, from which they are made by us. They are usually *tapered* in shape, but may be made *blunt* when required; are cut *double*, as in **Plate C**, and used for special purposes in place of the *round* or *half-round* files.

**CABINET FILES AND RASPS**—Are made of the sections shown in **Plate D**; from which it will be seen that they are both wider and thinner than the *half-round*, the sectional curvature being somewhat less than the *fifth* part of a circle. In shape, they are made *taper* from near the middle to the *point*. While both the files and rasps are made from 6 to 14 inches in length, 8, 10 and 12 inch, are the sizes in most common use.

As usually known, the *cabinet file* is a *bastard, double cut*, as in **Plate C**; the *cabinet rasp* is *punched, smooth*, as in **Plate E**;\* both the *cabinet rasp* and *file* are rarely ever made of any other degree of coarseness.

They are used by cabinet, saddle-tree, pattern and last makers, also by gunstockers, and wood-workers generally.

\* Great ingenuity was formerly displayed in arranging the teeth of *cabinet rasps*: some, rowing to the right, others, to the left; some, with spiral or circular—others, with crescent-shaped lines; these different arrangements having been given to meet the requirements, (which were often mere prejudices,) of the various trades. Such of these peculiarities, however, as were the result of mere prejudice, have given way before the changed conditions of labor, and the wiser views of the more enlightened mechanic, and are rarely found at this day.

**TRIANGULAR SECTIONS:**

**THREE-SQUARE FILES.**—These files are made from equilateral *triangular* sections, (as shown in **Plate D**,) commonly misnamed “three-square.” They are *tapered* to a small *point*, with considerable curve, and cut *double*, as in **Plate C**.

The larger sizes, say from 10 to 14 inches, are usually *bastard* or *2d cut*, and used to considerable extent in rolling mills; the smaller sizes are not unfrequently *smooth* or *dead smooth*, and are used in machine shops quite generally, for filing internal angles more acute than the rectangle, clearing out square corners, filing up taps, cutters, &c.

**THREE-SQUARE BLUNTS**—Of the smaller sizes, or from 3 to 6 inches, are sometimes made. They are mostly *2d cut* or *smooth*, *double*, and are principally used in machine shops, in filing up milling machines, and other cutters intended for working metals.

They were formerly used, to considerable extent, in smoothing the flutes made in the feed-rolls for cotton spinning.\*

**HANSAW TAPER†—Single Cut**—Are made from *three-square* sections, (**Plate D**,) and, in shape, are considerably *tapered*, like the three-square. They range in length from 2 to 12 inches, (by half-inches, below 6 inch,) the most common sizes, however, being from 3 to 5 inches, inclusive.

\* See Roller File. † See Handsaw Taper, Slim; and Double Ender.

They are cut *single* on their sides and edges, a short space at the point being left uncut. Unlike the three-square, their edges are first blunted or *set*,\* and then cut; after which, the sides are stripped† and cut, (*See Note.*)

As their name implies, much the largest use of these files is in the sharpening of handsaws, the angle of whose teeth usually correspond to those of this file. The *single cut* is considered to cut much *sweeter*, and to last longer, than the *double cut sawfile* of the same dimensions; this, however, will only apply, when the files are used on saws intended for wood.

The *handsaw taper, single cut*, or simply *Taper*, as it is commonly called, is, probably, the most generally distributed of any of the files known,—entering the household, as well as workshop,—and forms an important part of every file maker's business.

**HANSAW TAPER—Double Cut.**—Handsaw files are, to a considerable extent, cut *double*, and while they resemble the *three-square, double cut, file*, they are unlike it, in the very important feature of having their edges *set* and *cut*, like the *single cut sawfiles*. The sizes in common use are from 3 to 6 inches, though the larger sizes are frequently called for. Their three sides are usually *2d cut*.

NOTE.—The different methods pursued in cutting files made from three-square sections, as well as the difference in the results obtained, are too generally misunderstood, both by the dealer, and the mechanic who uses the file. The thin, sharp edges which are obtained in files described by us as *three-square*, are not unfrequently expected in the *sawfile*. The difference between the two files, (although the *sawfile* be *double cut*, and of the same coarseness as the *three-square*,) while not so marked as to constitute a distinguishing feature to the eye, is, in reality, a very important one, and consists in the *shape and cut of the edges*. In the *sawfiles*, both *single* and *double cut*, the edges, before being cut, are *set*, to give them the proper bluntness for durability; they are then cut, after which the sides are stripped and cut. In the *three-square* file, the edges are left very sharp, and are not cut; the two courses of cuts on each of the opposite angles, pricking through, and making exceedingly frail points or teeth on these sharp edges, having comparatively little durability, and being entirely unfit for the purpose of filing saws, which requires that the edges of the file should have teeth strong enough to do the work of *bottoming*, while the sides do the sharpening.

\* See Set. † See Stripped.

**Circular Sections.**  
of Round.

plate  
**D**

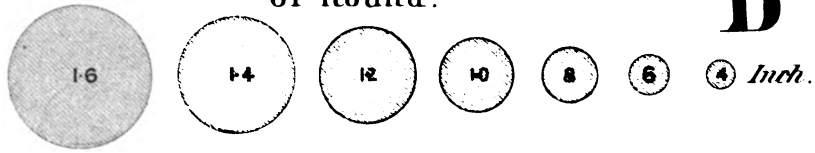

of Cabinet.

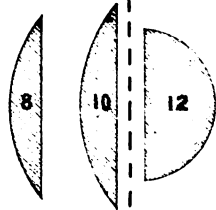

of Pitsaw.

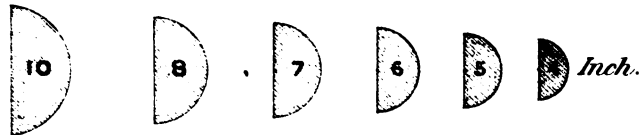

of Half Round.

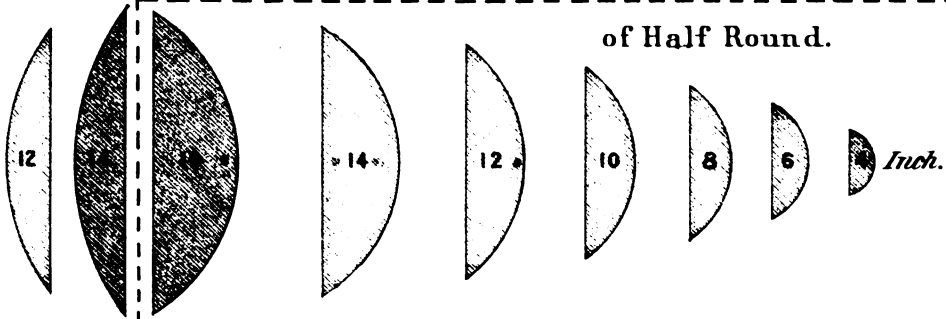

**Triangular Sections.**

of Three Square.

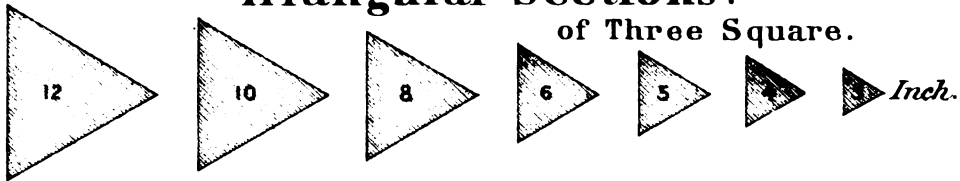

of Cant.

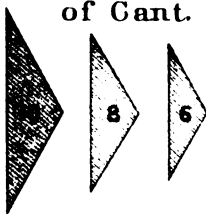

of Lightning.

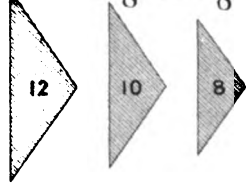

of Knife.

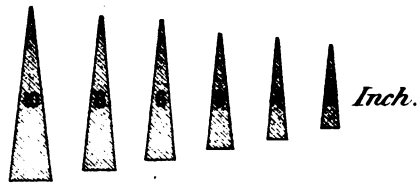

**Miscellaneous Sections.**

Cross.

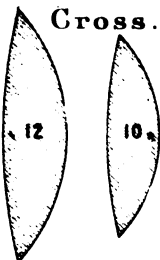

Feather  
Edge.

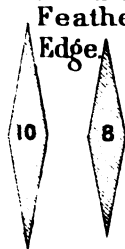

Shoe Rasp.

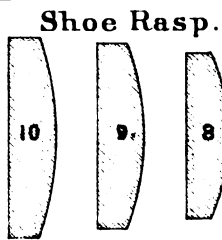

Reaper



Tumbler.





They are preferred by some, in filing the fine-teethed hand and back saws, also the metal workers' hack saws, which are considerably harder\* than those used upon wood.

**HANSAW BLUNT.**—Blunt handsaw files are not common, though the smaller sizes of sawfiles are sometimes made of this shape, both from the regular sections, and as *slims*.† They have their edges *set*, and are cut either *single* or *double*, like the handsaw tapers.

**BANDSAW FILES**—Are made both *blunt* and *taper*, of the smaller sizes of three-square sections shown in **Plate D**. In shape, they are like the *slim* handsaw files, except that their edges are blunted to a greater degree, and not unfrequently rounded; they should be cut somewhat finer than the regular handsaw files.

These files are used principally in filing bandsaws, the slenderness of which, would hardly admit of the teeth being filed to a sharper bottom.

**CANT FILES**‡—Whose cross-section is shown in **Plate D**, are principally used in shaping the inner angles of spanners or wrenches for hexagon bolt heads and nuts; the obtuse angle of the file being intended to correspond with those of the hexagon in shape.

They are usually made *blunt*, and cut *double*, mostly *bastard*, as in **Plate C**, on their three sides.

The *cant file*, (but little known in this country,) will be found a very useful instrument for the purposes described; 6, 8 and 10 inch being the usual sizes called for.

\* Saws that are quite hard may be filed with a *fine double cut*, if handled with care, when the *single cut* will fail to "bite,"—hence the preference for the *double cut* upon this class of work. The movement of the file, in all severe cases, should be slow, or the teeth will be "burnt" or stripped off, and failure will ensue. It is common with some mechanics, when work of exceeding hardness is to be operated upon by the file, to use turpentine, by the aid of which, it will bite, when under ordinary use, it would glide over and burnish the surface of the work.

† See Handsaw Taper, Slim.

‡ Hexagon nuts were formerly often called "six canted," from which the name *cant*, as applied to files, was undoubtedly derived.

**LIGHTNING FILES.**—See **Plate D**. The term “lightning,” as applied to a file, is known principally by those using the saws of this name, and to some extent, by those using other cross-cut, **M** shaped saw teeth, of which there are several makers.

The obtuse angle of this file is *five canted*, while the regular *cant* is hexagon, or six canted, and is found to be too obtuse, for the purposes required of the sawfile.

They are made *blunt*, and range in length from 4 to 12 inches, and are cut (except for a short space near the point,) *single*, on their three sides, like the ordinary *mill file* of the same length.

**KNIFE FILES**—Are of section seen in **Plate D**, and rarely exceed 10 inches in length, the principal sizes being 4, 5 and 6 inch. They are *tapered*, resembling somewhat, when finished, the blade of a knife; cut *double*, as in **Plate C**, and, in limited quantities, are in pretty general use.

The very acute angle which the sides of this file bear to each other, makes it especially useful in filing the inner angles of the sear and main springs of a gun lock, and works of a similar shape.

**KNIFE BLUNTS.**—Knife sections are also made *blunt*, while in other respects they are like the *knife taper*. When in this shape, their thin edges are used for finishing the teeth of small gear wheel patterns, beveling the sides of narrow grooves, enlarging the nicks of screw heads, &c.

**GINSAW FILES**—Are made from *knife* sections, and *tapered* in shape like the regular *knife files*; the sizes principally called for, being  $3\frac{1}{2}$  and 4 inch. They are cut *single*, on their sides and thin edge, similar to the handsaw files, and are employed in filing the saws used in cotton gins.



# Rasps.

Plate  
**E**

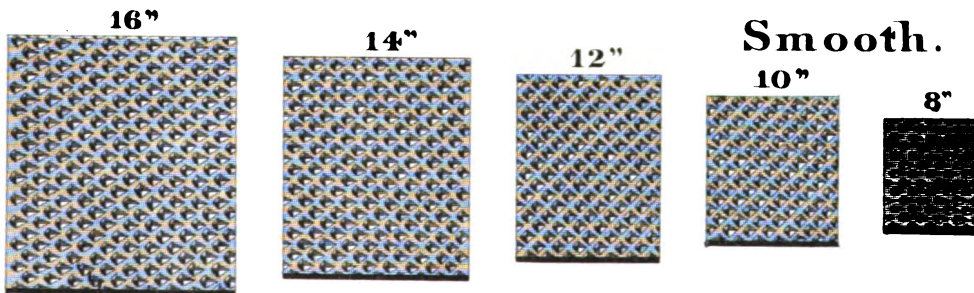
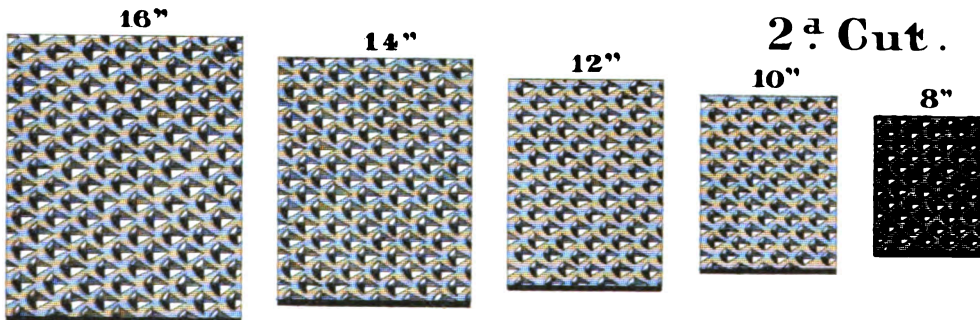
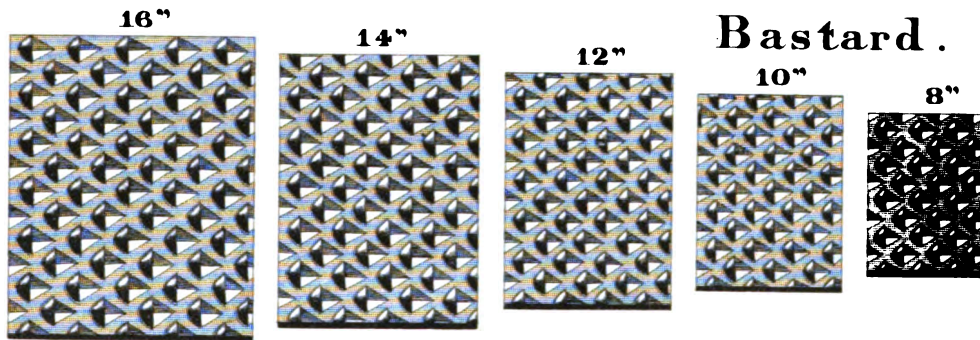
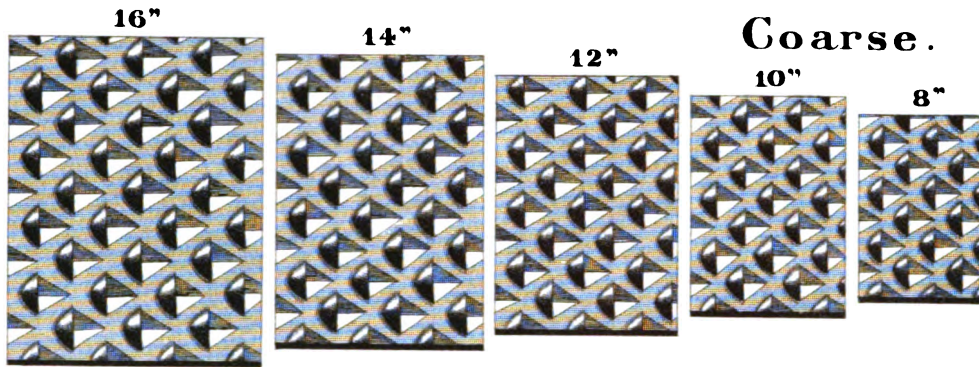



## MISCELLANEOUS SECTIONS:

**CROSS FILES**—Sometimes called *double half-round* or *crossing files*, (see cross-section, **Plate D**,) are in very limited use. They are made mostly to order, either *blunt* or *tapered*, and are usually cut *double*.

Their faces having different curvatures, they are found useful, in some cases, when a two-fold curvature in the same file is required.

**FEATHER EDGE FILES**—Are but little used by the general mechanic of this day. They were formerly used in filing "feather springs,"\* also the niches in curry combs, which led them to be called by some, *curry comb files*. The few files of this kind which are now made, are usually *blunt*, and cut *double*.

The acute angle of the *knife file* corresponding so nearly to those of the *feather edge*, it is found to answer for most purposes.

**HALF-ROUND SHOE RASPS**—As generally made, are of the cross-sectional shape shown in **Plate D**. The sizes range from 6 to 12 inches, although 8, 9 and 10 inch are the most common. They are made parallel in width, but with their sides slightly *tapered* from the middle; the ends are rounded and cut *single*, edges *safe* or uncut, while the sides are usually made *half file* and *half rasp*, *reversed*; ( $\frac{1}{4}$  and  $\frac{3}{4}$  *file*, while sometimes made, are the exception;) the *file quarters*, being *bastard*, *double cut*, as in **Plate C**, and the *rasp quarters*, *2d cut*, as in **Plate E**.

This form of shoe rasp is the one in general use at this time, and has almost entirely superseded the flat† and swaged rasps, formerly in use.

\* The sear spring of a gun lock is sometimes called *feather spring*. † See Flat Shoe Rasp.

**OVAL SHOE RASPS**—Sometimes called *French shoe rasps*,—are oval on both their sides, instead of on one, as in the half-round shoe rasp. Their sides are *tapered*, at each end, to a somewhat thinner point than the *half-round*, and are *punched*—half, *smooth, rasp*, and half, *2d cut, rasp, reversed*; their edges being left parallel and uncut. This form of shoe rasp is but little called for.\*

**REAPER FILES**—Are made of the cross section shown in **Plate D**. They range in length from 7 to 10 inches, slightly *tapered*, and cut *single*, on their sides only, the beveled edges being left safe. They are principally used for sharpening the knives of mowing and reaping machines.

**TUMBLER FILES**—Were formerly much used in filing the tumblers to gun locks, but are now very rarely called for. In shape they are *taper*, and cut *double*.

It will be seen by reference to the *tumbler* section, **Plate D**, that unless for some special purpose, the *pitsaw, round* or *half-round* sections will be found to answer.

Some of the files which are in quite limited demand, together with others which have almost, or altogether, passed out of use in this country; as also a brief definition of many of the terms pertaining to the manufacture of files generally, some of which are used by us in this work, will be found under the separate headings of **FILES SELDOM USED** and **TERMS DEFINED**.

\* See Flat Shoe Rasp.





## OUR SPECIALTIES.

While the files comprised in our previous text and illustrations, are supposed to be of the shapes, varied character of cut, and degrees of coarseness, best suited for general uses, certain kinds of work are greatly facilitated, and a considerable degree of satisfaction obtained, when the file is made with especial reference to the work to be performed.

We shall now describe some of these peculiarities in the file, as manufactured by us, which an experience of nearly fourteen years has taught us, render it most desirable for the special purposes hereinafter named.

We shall, also, in connection with some remarks on the manufacture of files, especially on the formation and grouping of the teeth, both when made by hand and by machine, refer to other desirable features found in files as made by us, prominent among which, is the **INCREMENT CUT.**

This will be followed by a few practical hints upon the art of filing, as well as upon economy in the use and care of the file, accompanying both of these points, with illustrations showing certain tools and appliances of our manufacture, which will be found to be efficient and valuable aids in both the use and care of the file.

**IMPROVED HORSE RASPS:**

PATENTED.



We present, herewith, an illustration of an ingenious arrangement of the teeth of *Horse Rasps*, from which it will be seen that the faces of each alternate row of teeth are presented to the work at reversed angles, producing an obliquity of the cutting edges, which gives a shearing or drawing cut. Thus, while the substance is cut away, instead of being torn, a much larger quantity of material is removed with the same power, than if the faces of the teeth were arranged at right angles to the edges of the rasp, as is the usual custom.

By this arrangement, the teeth are much more durable, their points being less liable to crumble in use; and, as will be seen from their principle of construction, they are less liable to become clogged; the refuse, instead of being *forced into the space* in front of the tooth, as in the old style, is, to some degree, by the very action of the operator, *pressed outward*, and thus made to *clear itself*.

Horse Rasps, of this brand, both *tanged* and *plain*, are made by us, of the usual sizes, from an extra quality of "mild" steel,\* each tooth having a double blow. They are tempered by a process which gives them a toughness believed to be unequalled.

\* Rasps were formerly made of "blister" steel, but of late years, it has been found practical to produce cast steel of a softness and tenacity to admit of raising a better and stronger tooth than could be done on "blister" steel; or cast steel, as formerly obtained; for this reason, principally, rasps found in the markets of this country at the present day, are of a much better quality than formerly.

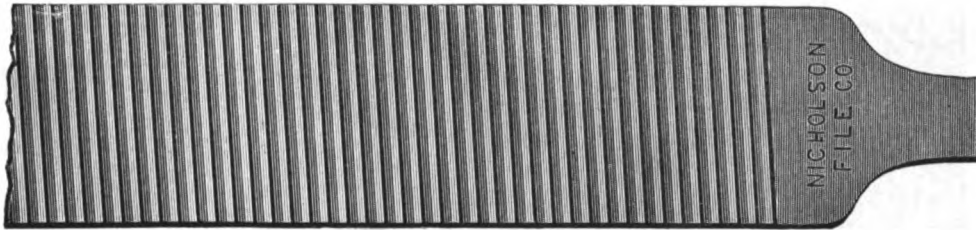
**Lead Float**

The above engraving represents the character and coarseness, of a 12 inch *single cut*, or *float*, used for filing lead, and designated by us as a *lead float file*.

It will be seen, that, unlike the *single cut* shown in **Plate B**, the teeth are nearly straight across the file, and very open, both these features being essential in a file to be used upon lead; for, were the teeth to have considerable obliquity, they would glide, and it would be difficult to properly guide the movements of the file; while the openness of cut, enables the operator to free the teeth from the lead, which would fill, and so clog them, as to render the file comparatively useless for the purpose intended, were a double cut, or fine single cut, to be used.

The variety of files made with this form of teeth, usually consists of 8, 10 and 12 inch *flats* and *half-rounds*. They may, however, be made to order, from other of the sections and sizes shown in **Plates A and D**.

While employed, to some extent, upon bone, horn and ivory, they are principally used by plumbers, and workers in lead, pewter and other similar soft metals, for whom, they are chiefly recommended.

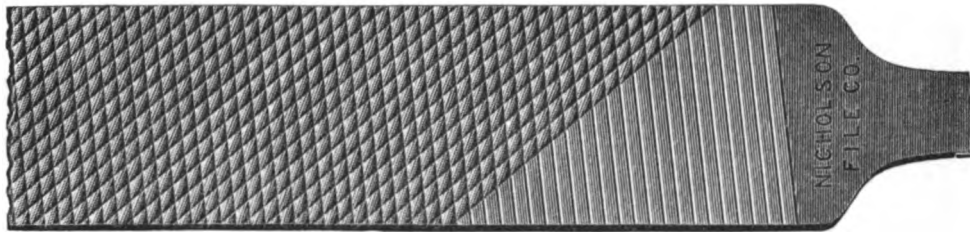
**BRASS COARSE:**

The file for cutting brass, above illustrated, being open in both its *over* and *up-cut*, is not expected to file fine, but "fast;" and is recommended, only, for very rough work on the softer metals; as in filing off the sprues from brass and bronze castings, filing the ends of rods, and work of a similar nature. It is also, to some extent, used upon wood work.

In filing brass with the ordinary cut and coarseness of file, as intended for general use upon the harder metals, the operator is not unfrequently deceived in the actual amount of stock he is displacing, inasmuch as from the ease with which the brass is worked, as compared with iron or steel, he is led to imagine that the file does not cut well; when, in fact, the real difficulty exists in the softness of the metal, and to overcome it, the operator should have a file that will penetrate the work deeper; he will then be able to remove more stock, and will necessarily feel the resistance he is accustomed to, in working upon the harder metals.

The above file will be found very useful for the class of work for which it is recommended, its openness of cut admitting of the desired penetration; if a finer finish be essential, the Brass File next described, should be used.

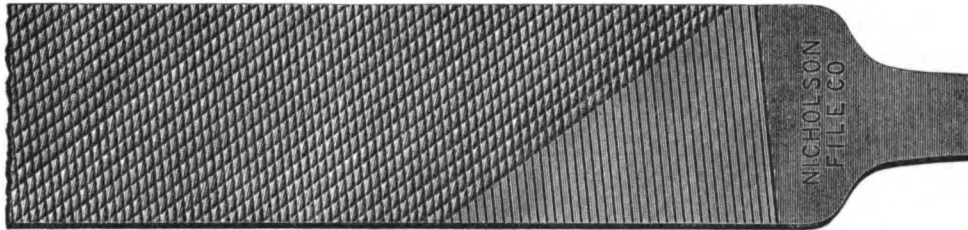

**BRASS BASTARD:**

We give, herewith, an illustration, showing the grouping of teeth for a *bastard brass file*, which, if examined in connection with the regular teeth as shown in **Plate C**, it will be seen that the *over-cut* is very open, and has considerable obliquity, while the *up-cut* is quite fine, and nearly straight across the file.

The essential difference between the brass file previously described, and the one herewith illustrated, consists, principally, in this degree of fineness of the *up-cut*, by which means, chiefly, the finishing qualities of the files differ.

This arrangement of teeth presents fewer cutting points to the work, than the regular cut file, but in a much more favorable condition for working the softer metals. While, from these peculiarities of their teeth, they cut more freely, and are less liable to clog, they also cut finer, more like the single cut file—which is not uncommonly used in finishing brass and bronze;—besides, by penetrating the surface of the work deeper, the usual resistance is felt by the operator, when the accustomed pressure applied to the harder metals is used.

This form of teeth, which may be applied to any of the finer cuts, and upon any of the shapes usually made *double cut*, is especially adapted to finishing brass, bronze, copper, and similar soft metals, and is not so well adapted to the rougher work upon these metals, as the *coarse brass file* previously described.

### FINISHING 2d CUT:

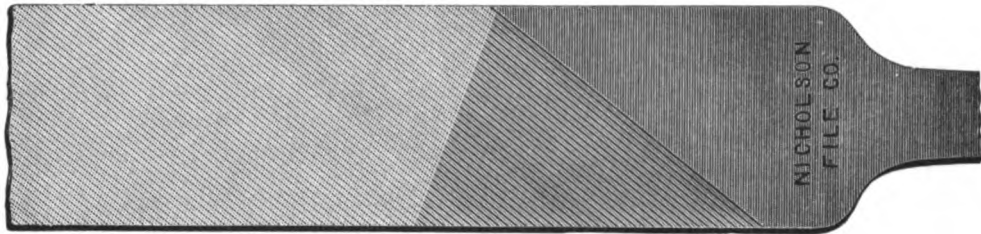

The file illustrated above, we designate as a *finishing file*. While its general appearance is not unlike the *brass file*, it is, in reality, materially different.

The first or *over-cut*, in this case, is very fine, and, contrary to the general rule, has the least obliquity; while the *up-cut* has an unusual obliquity, and is the coarser of the two cuts. The advantages in this arrangement of the teeth being, that the file will finish finer, and, by freeing itself from the filings, is less liable to clog or pin, than files cut for general use.

This form of cut is especially useful when a considerable quantity of finishing of a light nature, is required upon steel or iron. It is not recommended for brass or the softer metals, nor should it be made of a coarser grade than *2d cut*.

For, were the cut to be coarser, the file would, owing to the great obliquity of the *up-cut*, incline to glide out of the direction intended, and thus run in furrows; but with the *2d* or *smooth cuts*, the movement can be controlled by the operator, and the file will answer the purpose claimed for it, much better than the regular cut file.

**Slim**

**Handsaw Files**

Are made considerably lighter, but in every other respect, like the ordinary handsaw file; the lengths range from 4 to 12 inches (by inches only); being made from the sizes of *three-square* sections, stated below.

Lengths of Slim Handsaws.	4	5	6	7	8	10	12	inches.
Sizes of Three - Square Sections.	3	3½	4	5	6	8	10	inches.

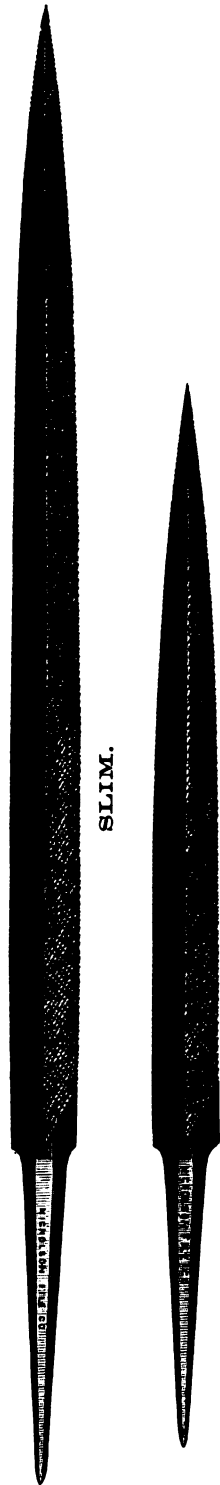

The *slim handsaw file*, is, to a considerable extent, taking the place of the regular pattern sawfile; the principal advantage claimed, (particularly amongst the smaller sizes,) being the greater sweep or stroke which is obtainable in files of a corresponding size.

The two cuts herewith given, show the comparative length of the slim and regular handsaw files, both being made from the same sized stock.

**DOUBLE ENDER**  
**HANDSAW FILE AND HANDLE:**

Patented January 1st, 1878.

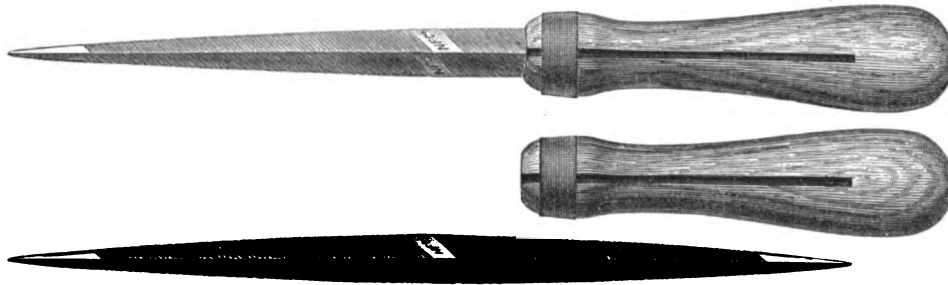

The above illustrations represent a new pattern of handsaw file and handle, also the two combined as when ready for use.

•We have, for a long time, felt, that a file so universally used as the handsaw file, could be presented to the public in a form that would more perfectly adapt it to their wants, and that, at the same time, it should be accompanied with a cheap and convenient form of handle, which could be instantly affixed.

Our Double Ender and its Handle meet both these ideas, and cannot, we think, fail to commend themselves to all classes in the community, who will give them a trial.

The advantages claimed for this form of file, consist in the variety of cut which is obtainable by having two files in one—such as one end double, and the other single; or one end fine, and the other coarse—as well as the perfect adaptability of both ends of the file to the handle; another advantage consists in the greater length of stroke or cutting surface which is obtained, over the ordinary sawfile, as usually made.

The handle is designed so as to be always ready for instant use on either end of the file, which it is especially adapted and fitted to firmly grasp.

These points will at once commend it to the mechanic, oftentimes, at great cost of patience, obliged to improvise a handle from the most convenient material within reach; and to the farmer, whose corn-cob is but an apology for one; as well as to the "amateur" filer, or tinker, in the shop or household, whose rude construction has proved itself but a poor substitute;—the result of all these devices being many a broken tang, and thereby useless files.

These files will be neatly put up in boxes containing six Double Enders and six Handles. They will be known as "Double Enders," and designated as follows:

No. 7,	Double Ender, single cut—represents two	$3\frac{1}{2}$ in. Taper Sawfiles.
No. 8,	" " " " " "	4 " " "
No. 9,	" " " " " "	$4\frac{1}{2}$ " " "
No. 10,	" " " " " "	5 " " "

Every parcel will be labelled and every handle stamped, in plain letters, with the words "Double Ender."

The genuine merit of the Double Ender, as a simple and useful combination, is as apparent as its economy, and these combined, render it so desirable an article for the consumer, as to at once command the favorable attention of the dealer.

The peculiar adaptability of this handle, will enable us, at an early day, to bring it before the public, in combination with other shapes and cuts, more particularly adapted to the several requirements of the different classes of mechanics.

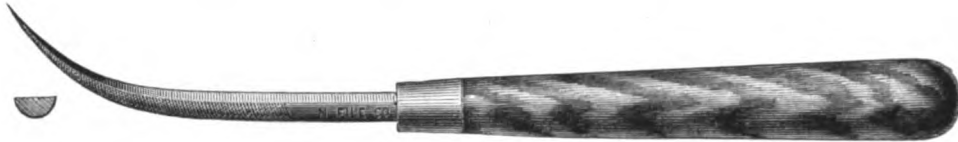
**BENT RIFFLERS—HANDLED!****HALF-ROUND BASTARD.****THREE-SQUARE RASP.****THREE-SQUARE BASTARD.****HAND BASTARD.****ROUND RASP.****FLAT FLOAT (Safe Sides).**

We present, herewith, a set of six Bent Riffers. The custom, hitherto, has been, to prepare this form of file on each end of a piece of steel, leaving the middle portion fashioned into a handle. By this form, one end is much in the way, when the other is being used. The form now presented will obviate this difficulty, and at the same time furnish a suitable handle for the better control of the Riffer, than by the old style.

Rifflers are used, principally, by carvers in wood, metals, marble and stone; also, in shaping and finishing in and about the many irregular places of pattern work.

They will be furnished and sold by the set, consisting of the six pieces herewith represented, neatly packed in strong paper boxes.

— — — — —  
↓  
**Roller File:**



The above cut represents a file designed for use in a machine, specially adapted to filing the flutes of feed-rollers, in cotton spinning machinery.

The sides are *planed* to the required angles, and to give the proper thickness to the edges.

They are usually made 4 inches long; are *2d cut, single*, on both sides and edges; and are of two sizes, known as Nos. 1 and 2, representing the thickness to which the edges are planed; the No. 1 having the thinnest edge, and being the size principally called for.

In their use, the files are grasped by a suitable holder in the filing machine, which clamps them to a true line, in the direction of their sides.

Three-square blunt files were formerly much used for this purpose, but owing to the changed shape of the grooves in the rollers, the sides of this file are found to be too obtuse.

Blunt knife files are also to some extent used, but having only one edge suitable for this purpose, they are found to be too expensive.

This form of file is well adapted to the work to be performed, and both its edges are made to do good execution.

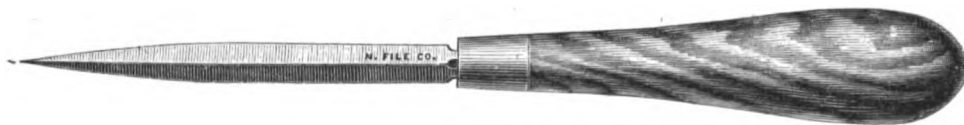
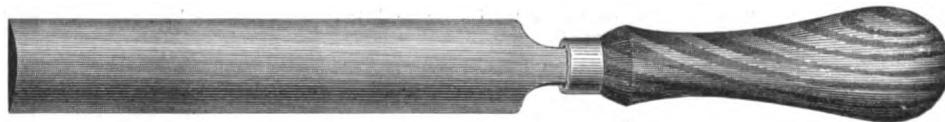
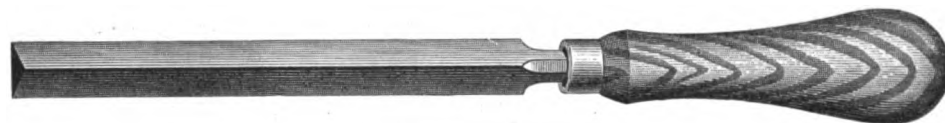
**SCRAPERS:****4½ IN. THREE-SQUARE POINTED.****6 IN. CANT.****10 IN. ROUND.****6 IN. HALF-ROUND.****4 IN. THREE-SQUARE.****6 IN. MILL.**

In view of the fact, that in the best appointed shops, the Scraper is an important, if not an essential tool; in most cases, but rudely prepared by the workman from old or worn out files; and considering the varied shapes of work to which these tools may be applied, if properly adapted, we have been led to make a suitable article for this purpose, which we have prepared for the market in sets of six



pieces, the shapes of which, it will be seen by reference to the illustrations, are adapted to a wide range of work.

The Scrapers are made as hard as possible, after which they are ground into the proper shapes.

As prepared and kept on hand for the market, the six pieces shown in the cuts, are made with blades 4 inches long, and are properly handled, constituting a set, which we shall call *Scraper Kit No. 1*; each set being suitably boxed. The price is fixed by the set.

Should parties require other shapes or sizes found in **Plates A** or **D** of file steel sections, they will be furnished (without handles,) tanged, tempered, and ground to the proper shape; and charged for, by the pound.

---

### Bread Rasp:



We give, herewith, an illustration of a Bread Rasp; a tool in quite general use, in other countries. It is the custom, with many of the better class of English and French people, in baking, to have their bread baked *quick and hard*, forming a thick, and, not unfrequently, burnt crust, which is afterward rasped down, until the harder portion is removed. Bread, thus prepared, is said to be much sweeter, and more palatable, than when cooked in the ordinary manner. Most of the large loaves and French rolls are baked in this way, the crumbs being used for soups, and in making rusks and dressing.

These rasps are neatly gotten up with nickel plated blades and enameled handles, and for the above purposes, as well as for preparing crumbs, will be found a useful implement. They will be prepared for the market, in boxes containing  $\frac{1}{2}$  dozen Rasps.

**FILE CLEANERS:**

Patented Feb. 12, 1878.

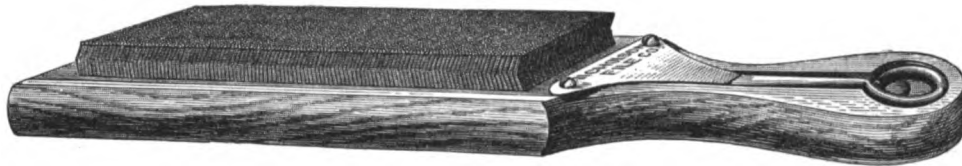

FILE CARD.

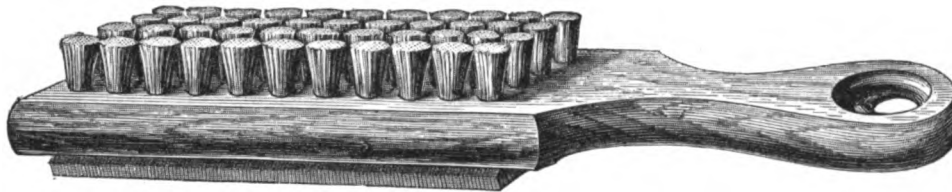

FILE BRUSH.

The illustrations, herewith presented, exhibit more convenient and durable forms of File Cleaners than are usually found, as, in most cases, they are prepared by the mechanic, by tacking old, worn out card clothing to a rudely devised handle, which, if not split by the operation, becomes, after a short use, detached and troublesome. The time, therefore, consumed in their construction and in keeping them in repair, to say nothing of the delay and annoyance resulting, has led us to believe that an article properly and durably constructed, would find a ready sale.

After considering the many applications to which this device should be put, on the different sizes and cuts of files, we have thought it advisable to construct the two forms herein shown—the File Card and Scorer for the more general use, and the File Brush, (combining the Brush, Card and Scorer,) for the use of tool makers and others, using the finer grades of files.

Of these devices little need be said, as almost every mechanic knows their utility in keeping a file free from filings. The Scorer is made of soft iron, and is used to remove the "pins," which fill up and clog the teeth, causing scratches in the work, if not removed. The Brush will be found a most efficient annex to the Card, especially upon finer files, removing the filings much more effectually than can be done by the Card alone.

The card clothing for these Cleaners is *new*, and firmly fastened to the handle (in a recess) with glue, which holds it upon its edges, as well as its bottom. The Scorer is held in a recess provided for its reception, by a spring, and while out of the way when not needed, is always ready for use. The hole in the handle is so shaped as to admit of the Scorer being removed with ease, and is also constructed so that the Card or Brush may be hung up when not in use.

They will be prepared for the market in boxes containing  $\frac{1}{2}$  doz. Brushes or Cards.

---

### FIG RASP:



The above illustration represents a useful file and rasp combined, as adapted to the use of fishermen, being cut on its sides only, as follows: one side is half, *rasp*, and the other half, *coarse, single cut*; while on the opposite side, both halves are *fine, 2d cut, single*.

The *rasp* and *coarse single cut* side, is used in shaping and finishing the lead weights or sinkers; while the opposite side, is adapted to shaping and smoothing the trolling bait, sharpening the points of fish hooks, and other work, of a like nature, necessary to the fisherman.

This *Fig Rasp* will be found a useful tool in the make up of a "kit," and, for a long time, has been in use by those who follow fishing for a living.

**FILE HOLDERS:**

Patented June 12, 1877.

**SURFACE FILE HOLDER.****WISE FILE HOLDER.**

The object of the inventions herewith illustrated, is to provide a device in which files may be firmly held for service in surface filing, and while in this condition, *readily sprung*, in order to give, at the will of the operator, more or less convexity to the working face of the file.

By the use of this device, it is not essential that files, to be used upon broad surfaces, should be selected with the care usually bestowed to obtain a true convexity or "belly" to their sides; the trouble of such selection, every master mechanic knows to be especially annoying and vexatious.

By its use, also, files may be more fully utilized, and made to render greater service than without it; *1st*, By insuring full use of the side, which, were the file crooked, could not, otherwise, be obtained; and *2d*, By being able, when the file becomes slightly dulled, by increasing its convexity, to lessen the number of teeth brought to bear upon the work, thus causing the lesser number of teeth which bear, to penetrate or "bite" the work, without increased labor bestowed by the operator.

The utility of the *Surface File Holder* will at once be apparent to the mechanic, in its application to broad cast iron surfaces.

The *Vise File Holder* will also be found a useful tool, particularly the smaller sizes, as, by its use, the file may be sprung to a degree enabling the workman to file in the exact spot required, (always important where nicety of finish is requisite,) in fact, utilizing the file in a manner never before accomplished.

These several file holders will be designated, and their range of sizes understood, by the following numbers :

Vise File Holder,	No. 1,	adapted to hold files	5 and 6 inches long.
" " "	" 2,	" " " "	8 " 10 " "
" " "	" 3,	" " " "	12 " 14 " "
Surface File Holder,	" 4,	" " " "	12, 13 and 14 inches long.
" " "	" 5,	" " " "	14, 15 " 16 " "

### MACHINE MILL FILES:

Files, of late years, are considerably used in machines, especially adapted to filing gang and other large saws, used in lumber mills.

The machine mill files are made *blunt*, usually 12 inches long, from the *mill* section in **Plate A**, and, while the edges are generally square, they are, to some extent, made round.

In cut, they are like the ordinary *mill* file, except that a short distance from the point is left uncut.

This form of file is preferred by many to the 12 inch mill file, for this purpose, although the latter is, to a very considerable extent, still used for machine filing.

### DOCTOR FILE:

From the *flat* and *hand* sections, we make files known amongst the calico printers as doctor files. They are made *equaling* in shape, usually 14 inches in length, and are cut *smooth, double cut*. (See **Plate C**.)

They are used for straightening the edges of "doctor plates."

**STUB FILES AND HOLDER:**

DETACHABLE.



PILLAR.



REAPER.



PITSAW.



THREE-SQUARE.



CABINET.



The above engraving represents a useful and economical device for holding prepared *stubs* or short files, for shaping and finishing in and around depressions, where the ordinary file could not be used.

The shapes of these stubs may be of almost any of the varieties shown in **Plates A and D**, and their cut, of any character, or degree of coarseness required, either as *rasp*, or *file*.

The character of cut will be varied to suit the work, and in ordering, the nature of the work upon which the files are to be used, should be stated.

This kit will be found to be of especial service in working either upon wood or iron, (as upon stove plate and soft metal patterns,) stone and zinc monumental work, also in sculptural work in marble, and other work of a similar nature.

The *holder*, (for which a patent is now pending,) is attached to the files by simply turning the handle, and thus, by means of a screw, forcing the jaws open, and into the recesses prepared for them in the file-stubs. The holder is released by simply turning the handle in the opposite direction.

The kit is prepared for the market in boxes, containing the *Holder*, and *six stub files*, 2 inches in length; their sizes and varied shapes will be seen by reference to the above illustrations.

**IMPROVED BUTCHERS' STEELS:**

Patented December 25th, 1877.



REGULAR STEEL.



PATENT STEEL.

We give, herewith, an illustration showing two forms of Butchers' Steels; the *Regular*, and *Patent Steel*.

In the sharpening of knives, two operations are essential; first, that of grinding or otherwise bringing the blade to a thin edge, after which, it is to be whetted, or its edge finished down to a proper condition for cutting.

The *Patent Steel*, above illustrated, is designed to perform both of these operations, being provided with two oppositely located cutting or abrasive surfaces, and two oppositely located smooth or finishing surfaces. The object being, that the knife may be brought to an edge upon the abrasive surface, and by a slight turn of the wrist, the steel changed into such a position, that the knife may be brought to bear upon the two finishing surfaces, without further change or trouble on the part of the operator.

In addition to the improved pattern, we make a steel from the same quality of stock, and of the same style of finish, which we call our *Regular Steel*, whose entire surface is *drawfiled* or *stripped*, after the manner of the well known "Wilson Steel."

These steels are manufactured from a superior quality of stock, made especially for this purpose, and are finished and mounted in a style unequalled in this line of goods; the handles being enameled in imitation of horn, jet and rosewood. Every steel stamped with our brand is warranted hard, and free from flaws.

We are now prepared to furnish the Regular or Patent Steels, in lengths of 10 or 12 inches, put up in lots of  $\frac{1}{2}$  doz. each.

**FILE-RASPS:**

(FLAT AND HALF-ROUND.)

Flat File-Rasps are in every way like the *flat files*, except in their cut; one side being punched, *bastard, rasp*, while the other side is cut, *bastard, double cut*; the edges being *coarse, single cut*. (See **Plates E, C and B.**)

The 14 inch is used, principally, for the nicer work in horse shoeing, in place of the regular horse rasps; being a favorite rasp with some of the fancy shoers. The 8, 10 and 12 inch being used, to some extent, by farmers, who thus obtain two *cuts* of teeth in one file.

The 8, 10 and 12 inch *half-round*, are made with the back, *rasp*, and flat side, *file cut*, as in the *flats*, and are used by farmers and wheelwrights.

**GANG-EDGER FILE:**

This is a blunt file, made from the *mill* sections. They are shorter than the regular mill, being made 8 inches long, from the 10 inch mill section.

They are cut *single*, like the regular mill files, and are especially well adapted to sharpening gangs of saws, (used in edging boards, in the machines known as "gang edgers,") without removing them from their arbor; also, in sharpening the knives of rotary planers, while on the cylinder.

**BOOT-MAKER FILE:**

These files are made somewhat lighter, but of the same cross-sectional shape as the *flats*, ranging from 12 to 18 inches in length.

They are cut *rough, single cut*, as in **Plate B**, on one side, and *coarse, double cut*, as in **Plate C**, on the other; the edges generally being left safe.

They are used by the larger boot and shoe manufacturers, for roughing down the pegs and nails, in finishing the bottoms of boots and shoes.





## MANUFACTURERS OF FILES

### STEEL:

Files are made from cast steel, more clearly defined as "Crucible Carbon," as distinct from the "Siemens-Martin," or "Bessemer" Steel, and until within a few years, it was imported almost exclusively from Sheffield, England. At the present time, however, very little is brought into this country from abroad; the American steel having been found to be of equally good quality, and in every way as uniform as the English.

And in justice to the American makers, we will here say, that our experience and tests have demonstrated, that the American steel contains, as a rule, a better quality of material than we formerly obtained in the English.

Steel, as prepared for files, is formed into the various cross-sections required, (as illustrated in **Plates A and D,**) and is furnished in bars of from 8 to 12 feet in length; to be afterwards cut into the requisite lengths to form the file blanks.

### **File Blanks:**

Files, whether cut by hand or machine, must first be formed into shapes, by some one of the well known methods of working this metal; after which, the blanks, as they are then called, must be annealed. They are then brought to the exact shape by grinding, before they are ready for the cutter.

In these operations, no little care must be exercised to ensure the best results, inasmuch as in each of them, the steel may be so injured, or such irregularity given to the shape of the blank, as when cut and hardened, the file will be found to be of inferior quality, if not totally unfit for use.

The blanks, in their several stages of preparation, are known by different names, as follows: when forged, as *black* blanks; when annealed, as *gray* blanks; when ground, as *bright* blanks; and are frequently sold to smaller makers, having little or no facilities for producing them.

In preparing the shape of the blanks, the custom for centuries has been, to perform the several operations by hand. The Trades Union element, which was so powerful among file makers in Sheffield, England, (until quite recently the great centre of this industry,) has had much to do with regulating, not only the prices paid for this work, but the kind of labor which should be bestowed upon it. As a result, until a comparatively recent period, machinery, in file making, has been slow of development.

This Company, during the past fourteen years of its existence, has spared no pains or expense in devising and otherwise obtaining the most perfect machinery, and we consider its use of no mean importance to the general results obtained in preparing the blanks.

### **Forging:**

In the forging, by the use of machinery, we are enabled to obtain greater uniformity in the shape of the point and body part of the blanks, and with much less liability of injury to the steel, than when performed by hand; while in forming the tangs, the advantages are

especially noticeable, as from the great uniformity in their shape, the consumer of files is enabled to effect a considerable saving in handles alone.

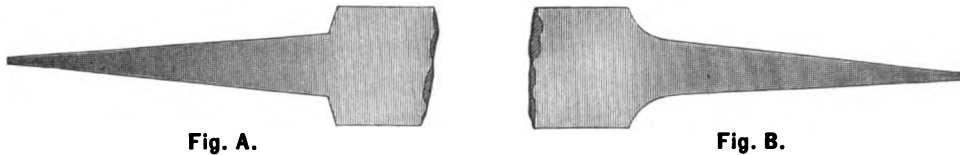

Fig. A.

Fig. B.

In this connection, certain peculiarities in the shape of tangs claim our attention.

The flats, hands, half-rounds, and similar cross-sections, as made by most of the hand makers, have tangs with nearly square corners, as in **Fig. A**. This form we consider decidedly objectionable, inasmuch as the corners are very liable to become weakened by fire cracks, and even if this were not the case, this tang is more easily broken, and the file thus rendered comparatively worthless.

The shape preferred, and as manufactured by us, is shown in **Fig. B**. Its greater strength is readily apparent, and it is much less liable to the objections referred to in the square shouldered tang.



Fig. C.

Fig. D.

Another feature is found in the shape of the tangs of square and round files, of the larger sizes, as made by most makers, and consists in tapering them, without shoulders, from the full size of the blank, as seen in **Fig. C**. The disadvantage of this form being, that it is especially destructive to handles, because of the great obliquity given to all its faces, thereby admitting of few other sections of files being used in the same handle.

To obviate these difficulties, we make our square and round tangs, of the larger sizes, as shown in **Fig. D**; a form, in our opinion, having sufficient strength, as well as the advantage of adaptability; the 12 inch square, or round tang, fitting the same handle as the 12 inch flat, or half-round, without unusual strain upon the handle.

**ANNEALING:**

After the blanks are forged into their proper shape, they are, while hot, usually thrown upon a ground floor, and allowed to cool under varied conditions; this gives them an uneven temper, and requires that they should be annealed before being ground.

This is usually done by piling them, in considerable quantities, in an oven, and subjecting them to a slow fire, until they obtain what is known as a *cherry red* heat; after which, the oven is closely cemented, and the blanks allowed to cool. If the operation is properly performed, the blanks are of a uniform softness.

Various contrivances are used by the different file makers, in the arrangement and construction of their annealing ovens; the principal object being, to obtain a uniformity of heat throughout the entire batch of blanks operated upon.

This operation, which is of material importance, as it affects the quality of the file when hardened, as well as the operations of grinding and cutting, is performed, by us, in ovens recently constructed upon the most approved plans, giving us a degree of uniformity in the blanks, hitherto unattainable.

After being annealed, the blanks are straightened or "smithed," as it is termed, when they are ready to be ground.

**GRINDING:**

This operation, which, until within a few years, was done entirely by hand, and by a majority of the makers, both in this, and the "old" countries, is still so performed, is now, by us, almost entirely done by machinery; a few, only, of the smaller sizes and irregular shapes, being ground by hand. By its use, a much greater uniformity and trueness of surface is obtainable.

The blanks, which, by grinding, have had the oxide or scale removed from their surface, and have been brought into the desired shape, are now ready for cutting; but before we take up this subject, we shall say a few words regarding the teeth of files.

### STRIPPING:

Before treating of the teeth, or cutting of files, something should be said about the operation of drawfiling the blanks, or what is known by the craft, as *stripping*.

While the blank, after grinding, may have, to the eye, an apparently true surface, if an attempt be made to drawfile it, slight irregularities will be at once apparent, and in order to remove these, the blank is subjected to the operation of stripping, or filing down to a true surface. If this is not done, the irregularities will be multiplied in the points of the teeth, when raised, and the efficiency of the file, to a greater or less extent, will be impaired; especial care should be taken upon blanks intended for the finer cut files.

This operation is usually performed by hand, and being a laborious one, is very liable to be slighted by the workman at the expense of the quality of the file. By the use of machinery, (the patents for which we control,) we claim that much more perfect surfaces can be obtained, than if the result was dependent solely upon manual labor.

### CUTTING:

**TEETH OF FILES.**—Much has been said and written upon the formation and arrangement of the teeth of files, both as made by machinery and by hand. Owing, however, to the exceeding difficulty of examining these minute points, even with a most powerful glass, it becomes a somewhat difficult matter to treat. That a difference exists in their shape, however made, as positive as in the turning tool or plane iron, and that it has an important bearing upon the general usefulness of the file, is certain; the arrangement or grouping of the teeth, is also an important and essential element.

The teeth of files, whether they are machine or hand cut, are formed by chisel cuts, or indentures, which force the metal above the

plane of the blank operated upon ; their shape and height depending upon the following conditions :

- 1st. The force of the blow applied to the chisel.
- 2d. The vertical inclination at which the chisel is held ; and
- 3d. The angles at which the cutting faces of the chisel are ground.

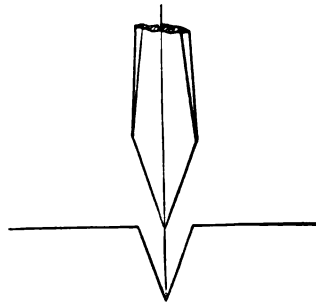

Fig. E.

While the first affects the height of the tooth, any change in the vertical inclination at which the chisel is held, or in the angles of its cutting faces, would more or less affect the shape of the tooth ; for instance, the chisel in **Fig. E** being held perpendicular, it is evident the indenture would be an equilateral groove, as the figure shows ; or, if it were held as in **Fig. F**, it is plain, that without any change in the angles of the chisel, a tooth would be raised whose cutting face would be *under-cut* or *hooking*. It therefore follows, that any intermediate angle of the face of the tooth may be obtained, by a simple change in the vertical inclination of the chisel. Similar results may also be obtained, by a change in the angle at which the edge of the chisel is ground.

We must then conclude that these several angles of the faces of the teeth in files, are not caused by any "*peculiar movement given to the chisel*" at the time the blow of the hammer is received, nor are they caused by a "*curved or drawing blow*," as is claimed by many of the hand cutters, but are, instead, *the results of natural laws*, capable of being produced as well by machine, as by hand labor.

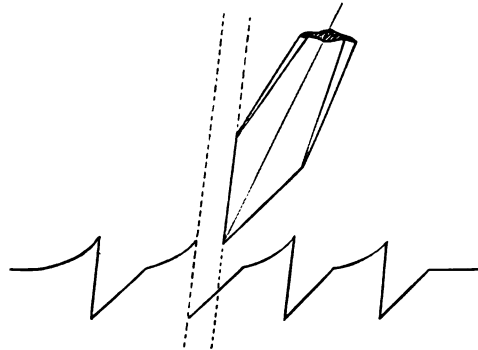

Fig. F.

A mistaken idea also prevails with some, that a good tooth can only be produced by hand, and with a chisel which is ground to a sharp knife edge, as represented in **Figs. E and F**. Now it is not the *bottom*, but a very small fraction of the *top* of the tooth, which does the cutting; and if the proper shape be given to the top of the tooth, its base, and bottom of the indenture, should be constructed not only with a view to obtain strength of tooth, and the proper angles for clearance, but with a special view to prevent "*pinning*," usually a source of much trouble and annoyance, especially upon finer files.

One of the principal causes of files pinning, will be found in the extreme acuteness of the chisel cut, *at the bottom of the indenture*, enabling the fine shavings or filings to become so firmly wedged into the tooth, as to require considerable labor in removing them; therefore, if the bottom of the indenture could be *blunted*, as illustrated in **Fig. G**, without otherwise impairing the shape of the tooth, the tendency to pin, would, in a considerable degree, be avoided.

While the edge of the chisel required to produce such a tooth as is shown in **Fig. G**, must be blunted, the edge of that face of it which produces the cutting face of the tooth, should be sharp, to give a keenness to the point of the tooth. Such a chisel will have an enduring edge, and the tooth which it forms will be largely freed from the tendency to pin, while its general shape will otherwise remain unimpaired.

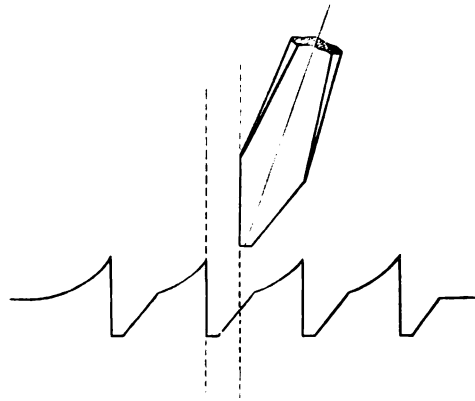

Fig. G.

By machinery, this form of tooth can be easily produced, inasmuch as the chisel, whatever its formation, is forced straight down into the blank with a precision depending only upon the ingenuity and accuracy with which the machine is constructed, and the nicety of its adjustment; while the difficulties in the way of the use of this shaped chisel, by the hand cutter, render the production of such a form of tooth well nigh impossible.

It sometimes happens in cutting files, that the chisel is continued in use after its edge has become so dulled or rounded, that it fails to make a clear cut; the effect of which is to round the face, producing "caps" to the tops of the teeth, as considerably magnified in **Fig. H.** This trouble is, of course, found in both forms of cutting, especially upon the coarser cuts; circumstances, however, attending the use of the chisel by hand, largely increase the tendency to produce such teeth.

In hand cutting, the operator not only deliberately dulls the *keen knife edge* of his chisel, (which would not otherwise stand,) by rounding it upon a whetstone, but during the operation of cutting, as deliberately drags it along the blank, in feeling for the last tooth produced. Thus, from the very nature of this operation, the tendency is, by *whetting, dragging and wearing*, to round the chisel's edge very rapidly, requiring, as is well known, frequent sharpening.



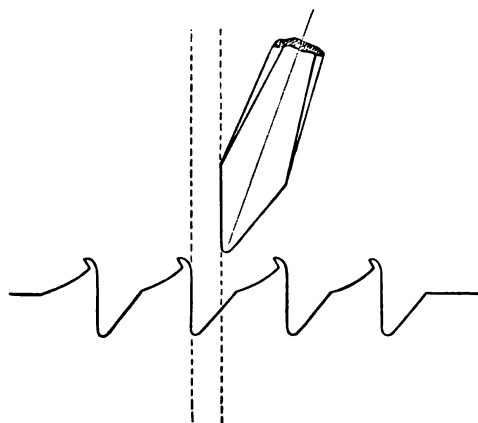

Fig. H.

to produce sharp teeth—Whereas, in the machine, the feeding of the blank is intermittent, the cutter coming in contact only when the actual impulse is given to force it in the desired direction, straight down into the blank, to produce the tooth; the cutter's edge is thus capable of being shaped with a view to produce the best possible form of tooth, and by the precision and direction of its movement, it will retain its keenness much longer than if used by hand.

Files having capped teeth are not necessarily unfit for use, as these caps are very minute, and upon the first use, crumble off, and, in many cases, the file does good execution.

It is, perhaps, hardly necessary to state, that the **Figs. E, F, G,** and **H,** are largely magnified in order to more clearly illustrate the shape and angles of the teeth shown in each case; nor to state that few files are ever produced, in which the cutting faces of the teeth are hooking, or even perpendicular—the faces of the teeth on fine files usually sloping back from a perpendicular line, from 2 to 5 degrees, and on the coarser grades from 5 to 10 degrees. Were the teeth to be hooking, it would be almost impossible to keep the minute filings or “shreds” from wedging into the spaces between the teeth, or pinning.

This brings us to consider the different modes of cutting—by hand, and machinery.

**HAND CUTTING.**—In cutting files by hand, the needed tools are so simple, that, without doubt, those now in use, are similar to what the hand cutters of generations past must have used.

To the casual observer, the operation of hand cutting, especially when the accuracy of spacing is considered, appears to be one requiring a remarkable degree of skill ; a slight familiarity, however, with the details, will at once prove it to be far less magical, than at first sight, it would seem.

In this business, as in all others, the skillful and finished workman is known by the quality of the work he produces ; the operation requiring certain attention to keep the tools in order ; no such wonderful gifts, however, are required but that much of the work is performed by boys, the tendency in this direction increasing in proportion to the fierceness of competition, necessitating the production of the goods at less cost.

In cutting files by hand, the operator is seated before an anvil of special construction, which is mounted on a block ; the blank to be operated upon, is, by means of the feet, held down to the anvil by two leather straps, the tang end of the blank being toward the operator. With a chisel in one hand, held at the proper angles, and a hammer of a peculiar shape, in the other, he strikes his first blow upon the chisel, which is placed at the point of the file ; this throws up a barb or ridge, extending across its surface.

The chisel is then replaced on the blank, and is slid up until it encounters the barb already made, when the second blow is given, and so on, until the first course of teeth is completed, so far as this face of the file is concerned.

The first course of teeth must then have their rough edges smoothed off with a file, so that the chisel will glide over them easily, before the second course (if the file is to be double cut) can be made ; which is done by reversing the angle at which the chisel is placed upon the blank, and proceeding in precisely the same manner as in the first course.

Now, as the spacing is regulated by the height of the ridge which has been thrown up, and this ridge, in turn, is dependent upon the impulse given to the chisel which produced it, it therefore follows, that the regularity of the work must depend upon the skill of the operator—affected, as it must be, by his habits, moods and temperament.

We conclude then, that all hand cut files, must, from the nature of their construction, have a greater or less degree of irregularity in their teeth; that the more unskilled the workman, the greater will this irregularity be found to exist, and the more skillful the workman, the nearer will his work approximate to the controllable regular irregularity of our machine cutting.

**MACHINE CUTTING.**—It was not until a comparatively recent period that files were successfully cut by machinery. The first account we have of any attempt in this direction, is of an invention by one Duverger, in 1699. Several attempts were made during the eighteenth century. In 1800, a Frenchman named Raoul, invented a machine and commenced to produce watchmakers' files, which were spoken of, years ago, as being "beautiful specimens of workmanship, and less liable to clog and pin, when in use, than when cut by hand."

The beautiful, small, Swiss and French files for dentists, watchmakers and similar uses, now found in some of our markets, are also said to be made by machinery.

The difficulty attending the introduction of machinery in cutting the larger files in general use, was not practically surmounted until within the past fifteen or twenty years. At the present day, however, much the larger proportion of the files made and used in this country, are machine cut.

In the various machines which have been invented for cutting files, we find the prevailing tendency has been, in their arrangement, to produce *equidistant spacing in the teeth*, from the point to the tang of the file; such extreme regularity causing, in double cut files,

when put to use, channels in the work, the exact counterpart of the equidistant grooves to be found in the file; and in single cut files, a chattering and jarring sensation, at the least, not pleasant to the operator.

Files having their teeth so arranged, require much greater pressure to compel the teeth to take hold of the work, than were they irregularly intermingled; especially would this be noticeable on broad surface filing, for while files thus made may have well formed, sharp teeth, they will be found to have an apparent dullness, when applied to broad surfaces, arising from the greater effort required in causing the increased number of teeth brought to bear upon the surface of the work, to bite.

It should be borne in mind, that most mechanics have been taught to use irregularly cut, hand made files, and are not accustomed to apply an increasing pressure when filing, in proportion to the increased number of teeth which come in contact with the work, naturally preferring to exert the least possible labor in causing the file to penetrate.

Hence it is, that machine files, having equidistant spacing, while they may answer a good purpose upon some classes of work, have not, as yet, supplied the place, either of the Hand made, or the Increment, irregularly spaced, machine made files.

**INCREMENT CUT FILE.**—In the machine cut file manufactured by us, and designated as the “**INCREMENT CUT**,” the essential requisites, necessary to produce a perfect file, are believed to be met, and the several objections to the equidistant spacing entirely overcome.

The arrangement of the teeth of this file may be described as follows:

- 1st. The rows of teeth are spaced progressively wider, from the point toward the middle of the file, by regular increments of spacing; and progressively narrower, from the middle toward the heel, by regular decrements of spacing.

- 2d. This general law of the spacing of the teeth, is modified, by introducing as they are cut, an element of *controllable irregularity* as to their spacing; which irregularity is confined within maximum and minimum limits, but is not a regular progressive increment, or decrement.
- 3d. In arranging the teeth of files, so that the successive rows *shall not be exactly parallel*, but cut slightly angularly with respect to each other,—the angle of inclination being reversed, (during the operation of cutting,) as necessity requires.

Files possessing the characteristics above mentioned, do not produce channels or furrows in the work, but effect a *shearing cut*—for the reason that no two successive teeth, in any longitudinal row of a cross cut file, are in alignment; the file is thereby able to cut more smoothly and more rapidly, and possesses greater endurance as a tool for dressing metal, than any file whose teeth are not disposed upon the same principle.

The advantages of this arrangement cannot, perhaps, be better stated, than by quoting from an article on Files, in "Johnson's New Universal Cyclopædia," which says of the "Increment Cut File," "The difference between this, and the perfect regularity of other kinds, must be apparent, particularly in double cut files; as in the one case, the file cut with such extreme regularity, when put to use, will, in the first inch of its movement, produce channels or grooves, and these grooves will continue to be made deeper as the file is shoved along, thus producing that "grooving" and "chattering" so often complained of; while with the Increment Cut File, the grooves made by the movement of the file for the first inch, will have their sides cut away, as the file is moved toward the tang or handle, and *vice versa*; and while it is cutting as fast as its points permit, it is also said to cut smoother than the best hand cut file of the same coarseness. The irregularity spoken of, consists not only in the space between the teeth, but also in the height of the teeth

themselves. The object of having the teeth of different heights, is to admit of their being held down to the work, with less effort on the part of the workman."

Files of this description can only be produced by machinery of the character of that, for which several Patents were granted to this Company, and cannot be produced by hand, in any quantity; and as a distinctive article of manufacture, are covered by numerous Letters Patent, controlled by us.

**DEDUCTIONS.**—Reviewing the several points touched upon in this brief article on the *teeth*, and their *arrangement* upon the surface of a file, we arrive at the following conclusions:

- 1st. That there are no peculiarities in the formation or shape of the tooth of a file, as made by hand, that cannot be made by machine.
- 2d. That teeth can be so formed by machinery, without impairing their general shape, as to largely prevent "*caps*" and the tendency when in use to "*pin*."
- 3d. That neither the *extreme* regularity of most machine work, nor the *uncertain* irregularity of much of the hand work, is most desirable in files for general use.
- 4th. That while most files should have teeth, both irregularly spaced, and of irregular heights, the degree should be strictly under control, as in the Increment Cut File.

### **HARDENING:**

After being cut, the files are stamped, or branded; they are then ready for hardening. In this operation, the first thing necessary is to cover the teeth with a coating of paste, to protect them from any damage in the subsequent process of heating. The files are then put

into a drying oven, where they are allowed to remain until the paste becomes hard ; after which, they are gradually heated to a *red* heat, and immediately dipped in the hardening bath.

The teeth are then brushed—or scrubbed, as it is termed—to clean them from the paste, when they are rinsed in several waters, the last, being in lime water, where they are allowed to remain for some time, in order to neutralize any tendency to rust. They are then dried and oiled, when the tangs must be softened to prevent their fracture, by heating them in a bath of lead, and allowing them to cool in oil.

Considerable skill and good judgment is required in the operation of hardening, owing to the various shapes, and their often unsymmetrical sections ; some, requiring to be immersed quickly, others, slowly ; some, vertically, others, obliquely ; according to the form of the file ; that mode being adopted, which is best calculated to keep the particular shape, being hardened, straight.

With this precaution, it not unfrequently happens, that the file inclines to crook in cooling ; this tendency is overcome to a greater or less extent, by forcing the file at the crooked point, back to, or beyond, the straight line, and while under strain, in that position, pouring cold water on what was the *concave* side, which “sets” it in nearly that position in which it was strained. This operation is very dextrously performed by the skilled workman, but only when the file contains sufficient heat, as after it becomes once set throughout its entire body, no amount of strain will change it.

Some makers attach very great importance to the coating of paste, and medication of the hardening bath, keeping the wonderful secrets of their composition, sacredly, from each other. If we were to believe all that is said of their miraculous power to redeem and improve the stock, we should be strongly tempted to use an inferior steel, and trust to their curative powers for the result. Good steel, however, properly treated, requires no artificial compounds to redeem or improve it.

Undoubtedly, the teeth should be well protected from the effects of the heat, and the coating should be so prepared, that when the file is immersed, the action of the water should readily free it from the file; both the temperature and specific gravity of the bath, are of some importance; the first, as affecting the degree of hardness, and the second, the straightness of the file. All these points are well understood by the better class of mechanics of our day, upon whom these wonderful secrets make but little impression.

### **INSPECTING AND TESTING:**

In all manufactories in which any considerable quantity of cutting tools are produced, the necessity of a critical inspection after the various operations in their manufacture are completed, and the advantages of frequent inspections, must at once be apparent.

In every important manufactory, some form of inspection will be found to exist. Whether it be when the article is completed, or more or less frequent during the processes of manufacture; whether by skillful and disinterested inspectors, or, as is not unfrequently the custom, trusting to the workmen entirely, will depend, very largely, the character and quality of the work produced; and the proper execution of the system, will be found to hinge upon the stamina of the maker, and the degree of pride felt in his manufactures.

The system pursued by this Company, is, to employ competent persons to inspect the work at the several stages of its manufacture; and upon their report, the workman is paid.

By this system, not only a very much less number of imperfect files is obtained, but even the "seconds" and "wasters" are of a much superior quality than would ordinarily be the case, if the files had but one inspection, and that, when finished—as when the causes which result in a large percentage of second quality exist, it is evident that the standard of both qualities must be lowered.



Inspection, therefore, at each stage during the manufacture, we consider of importance, irrespective of the final examination, which is made after the file has been hardened.

In this final examination, the files are *Tested* by us, upon hardened provers, to ascertain if they are sharp and uniformly hard; *Rung*, or struck upon a block of metal, to discern if they are sound, and free from fire cracks; and *Inspected*, to see if there are no miscuts in the teeth, or previously undiscovered imperfections in the general shape, or in the stock. If found imperfect in any of these points, it is sufficient cause to discard them as first quality files; those rejected have their brand ground out, and such of them as are suitable, are classed as second quality; the balance as "wasters" or scrap.

The files, after the final inspection, are to be properly cleaned and oiled, when they are ready for papering, and packing for the market.

### **PACKING AND BOXING:**

Until within a few years, all files were put up in paper packages, in lots ranging from  $\frac{1}{2}$  to 3 dozen in a package.

This system has materially changed during the past few years, in order to better adapt it to the wants of both consumer and dealer, especially in the manner of packing the smaller sizes, by putting them up in suitable paper boxes, all neatly and plainly labelled, both on the end and top, and holding  $\frac{1}{2}$  or 1 dozen files each.

In the smaller sizes, this is a marked improvement over the old system. For the larger sizes, or files exceeding 10 inches in length, it is not as desirable, as the ends of the boxes, by the great weight of the files, are too liable to be broken in transportation. We prefer, therefore, to confine this system to files under 10 inches in length, depending upon their weight.

Foreign files are largely packed by the manufacturers in casks, weighing, when ready for shipment, upwards of 500, and sometimes, even 800 pounds. For the home market, we now pack in boxes, containing on an average from 28 to 30 dozen files, and weighing about 130 pounds.

This form of shipment is, to a great extent, due to the quick and daily lines of transportation, which enable the dealer, or consumer, to carry a much lighter stock than was formerly possible, giving orders more frequently, and in smaller lots.





## POINTS ON FILING

Very few mechanical operations are more difficult than that of filing well. Unlike the tool fixed in the iron planer, whose movement is guided by unyielding ways, the file must be guided by the hand, and the accuracy with which this is done, will depend largely upon the patience and perseverance given in practice: the "guiding principle," involved in many other tools and operations, being wanting, in most applications of the file.

A severe test in filing would consist in producing a *true flat surface* upon narrow work, or say that whose width does not exceed one-eighth the length or stroke of the file. To the uninitiated, this would seem to require that the file should have a perfectly true and straight surface, but were it practicable to make the file absolutely flat and true, it would then be necessary to move it in absolutely straight lines across the work: even were this operation possible, the pressure, if applied at each end of the file, as is the usual custom, would give it sufficient spring to cause a slight concavity to its cutting surface, and thus an inevitable rounding to the surface of the work must be produced.

Therefore, to produce a flat surface, under this severe test, or even under more favorable circumstances, the file should have a convexity given to its surface.

**CONVEXITY IN FILES.\***—Undoubtedly, few, even of the old filers, have given the subject of convexity as it bears upon broad surface filing, the thought it is entitled to. It is known to many mechanics that a file which will *bite* and *cling*, with the accustomed downward pressure, upon wrought iron, or soft steel, will require a greater pressure to prevent it from *glazing* or *slipping over* the work, when applied to broad cast iron surfaces. This is owing to their glassy nature, and their extremely granular formation, requiring that the teeth should enter the surface deeper than in the more fibrous metals, or they will soon glaze over, and become dulled or shiny, thus giving to the file the appearance of being soft, while the contrary may be the fact.

Considerable convexity is, therefore, needed in such cases; for, while it gives greater control of the file from point to heel, it also presents fewer cutting points to the work, with a given pressure downward, than in the less convex file—the *bite being increased in proportion to the increase of the convexity*—the ability, therefore, to increase it more or less, at the will of the operator,† is of considerable importance.

\* Formerly, in the manufacture of files intended for use upon flat surfaces, it was the aim of the maker to allow sufficient convexity to their faces, to provide against the changes or errors incident to the several processes of manufacture, securing when finished, a convexity to each side, as in Fig. 1; though from the uncertainty of these changes, the sides might differ somewhat, in their degree.



Fig. 1.



Fig. 2.

At the present time, however, few makers will be found who do more than *taper the point of the blank*, either in the forging or grinding, leaving the finished file tapered from the point to near the middle; the body, from the middle to the tang, being parallel, as in Fig. 2. A system which, owing to the uncertainty in the operation of hardening, leaves much the larger proportion of the files, when finished, with one side more or less concave, a shape totally unsuitable for surface work.

It is our aim in the manufacture of this class of files, to obtain a convexity from point to tang, as shown in Fig. 1, regardless of the increased trouble and expense incurred.

† See File Holders, page 40.

In finishing many kinds of work, the absence of a suitable convexity limits the usefulness of the file ; as in the preparation of the valves of steam engines, tables of printing presses, stereotype plates, or other work requiring a true surface.

While an absolutely true surface is confessedly unattainable, it is evident, that, as in the above cases, a degree of perfection is sometimes desirable, beyond what the necessities of other work may require ; and to be able to touch the exact spot indicated by the straight edge or surface plate,\* with the file, is to utilize it in a manner which could not be done, if the convexity did not exist.

**FILES PROPERLY HANDLED.**—Before using the file, it should first of all be properly handled ; not, as is too often the case, by driving the handle half way onto the tang, and thereby doubling the chances of breaking it, but by forcing it well up to the shoulder. Some of the file handles found in the market will not stand this amount of driving, without splitting ; in such cases, the tang of an old or worn out file, of similar dimensions, should be heated, and the hole in the handle burned out to nearly the desired size and shape, before driving it onto the tang. It not unfrequently happens that the tang hole is not drilled central, or is badly out of line ; this may also be corrected by using a heated tang.

Of the many file handles of special construction hitherto devised, there are none which have, as yet, combined that simplicity, utility, and economy, necessary to take the place of the ordinary wooden handle ; nor do we think it possible to be improved upon, for many applications of the file, provided it be properly affixed, and carefully used.

There are, however, in every shop, many cases requiring a special application of the file, in which it should be firmly and positively fixed to the handle, not only as a means of safety to the workman,

\* See Surface Plate.

by preventing accidents, (such as might arise from the sharp point of the tang, in case the file became suddenly detached from the handle,) but to more firmly hold the file when considerable pressure is needed, as when filing internal apertures, or working into the many places where the power can only be applied to the handle end of the file.

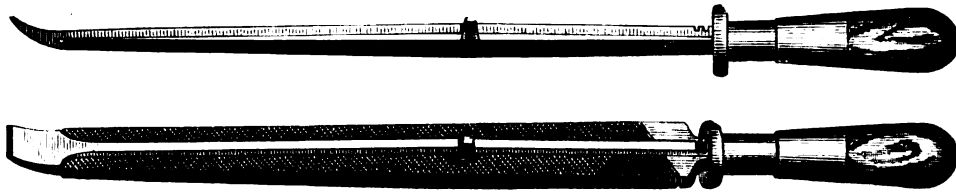

The *Vise File Holder*, herewith represented, (see description on page 40,) is not only intended to accomplish these objects, but it also enables the artisan to more fully utilize the file than can be done by any other means of holding it. It is especially adapted for use upon files 10 inches and under in length, which may be sprung, either to produce, or increase, a curve or belly; and thus while the file is stiffened, it may have its entire working face brought into contact with any desired spot of the work.

**DEVICES FOR HOLDING FILES.**—The file, when used in the ordinary manner, considerably exceeds the length of the work; but when such is not the case, as in filing large table surfaces, and shaping out recesses of considerable length, or when, from other causes, the ordinary handle will not answer, it then becomes necessary to grasp the file by holders of special construction. These special devices (many of which are quite rude) are numerous, and vary to suit the particular shape of the file, and the work to be performed.

Short pieces of files, of special construction, are sometimes clamped to the slide rest, to be used upon work revolving in the engine lathe, and are soldered, or screwed to bent handles, when required to be used in finishing in and around the bottoms of shallow cavities.

The necessity, however, of this last and troublesome method of holding the file may be avoided, by the use of the Stub File Holder, described on page 42.

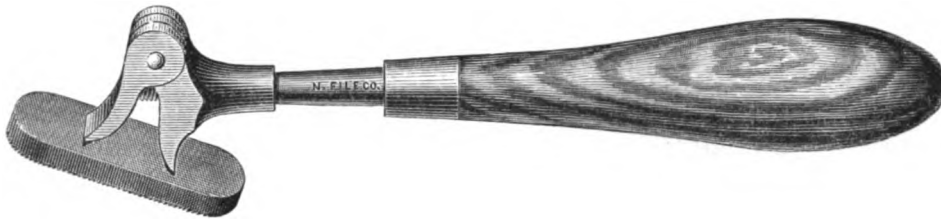

Wood workers not unfrequently clamp one or more files to pieces of board, or fasten them by means of staples and wire pins, or by cutting in, in such a manner as will enable them to smooth out grooves, or true up the edges of their work, using the board or holder as a gauge.



Bent Rifflers (a very convenient form of which is described on page 35) are sometimes required in reaching certain irregular shaped cavities.



Fig. K.



Fig. L.

In filing large table surfaces, the tang is frequently bent upward, as in **Fig. K**, to admit of the hands clearing the work, when the file passes over the surface; sometimes a crank-shaped holder is employed, having one end fitted to the tang of the file, while the other is fitted to receive the handle, as in **Fig. L**. These devices, which facilitate somewhat the handling of the file, do not give that perfect control which enables the operator to manipulate it at will, nor do they aid in governing its convexity.



The Improved *Surface File Holder*, herewith illustrated, (a description of which will be found on page 40,) is designed especially to meet these points; thus enabling the skillful operator to do much of the work with the file, which has hitherto been done with the scraper.\*

To have the file truly and firmly handled, or properly affixed to a suitable holder, is the first step in point of economy, as well as in the production of good work.

**HEIGHT OF WORK.**— Various ideas very naturally exist amongst mechanics, as to the height at which the jaws of the vise should be set from the floor, for use in filing; arising largely, no doubt, from the varied nature of the work upon which the advocates of the different ideas have been accustomed to operate.

For filing general work, the top of the vise jaws should be placed so as to be level with the elbow of the workman, which will be found to range from 40 to 44 inches from the floor—therefore 42 inches may be considered as an average height, best suited for all heights of workmen, when the vise is to be permanently fixed.

If the work to be filed is small and delicate, requiring simply a movement of the arms, or right hand and arm alone, the vise should be higher, not only in order that the workman may more closely scrutinize the work, but that he may be able to stand more erect.

If the work to be filed is heavy and massive, requiring great muscular effort, its surface should be below the elbow joint; as the operator stands further from his work, with his feet separated from 10 to 30 inches, and his knees somewhat bent, thus lowering his stature;

\* See Scrapers.



besides, in this class of work, it is desirable to throw the weight of the body upon the file, to make it penetrate, and thus, with a comparative fixedness of the arms, depend largely upon the momentum of the body, to shove the file.

It will therefore be seen, that in fixing the height of the vise, the nature of the work and the stature of the operator should be considered, if it is deemed necessary to apply the principle correctly.

**GRASPING THE FILE.**—In using the larger files, intended to be operated by both hands, the handle should be grasped in such a manner that its end will fit into, and bring up against, the fleshy part of the palm, below the joint of the little finger, with the thumb lying along the *top* of the handle, in the direction of its length; the ends of the fingers pointing upwards, or nearly in the direction of the operator's face.

The point of the file should be grasped by the thumb and first two fingers, the hand being so held as will bring the thumb, as its ball presses upon the top of the file, in a line with the handle, when heavy strokes are required. When a light stroke is wanted, and the pressure demanded becomes less, the thumb and fingers may change their direction, until the thumb lies at a right angle, or nearly so, with the length of the file; the positions changing more or less, as may be needed to increase the downward pressure.

In holding the file with one hand, as is often necessary in filing light work, pins, &c., the handle should be grasped as already described, with the exception that the hand should be turned a quarter turn, bringing the forefinger on top, and lying along the handle nearly in the direction of its length. In this position, the freest action of the hand and wrist may be had upon light work.

Amateurs will find that by following these directions, the movements of the file will be simplified, and made somewhat easier than if grasped at random and without consideration.

**CARRYING THE FILE.**—The most natural movement of the hands and arms in filing, is to carry the file in circular lines, the several joints of the limbs being the centres of motion; this movement of a convex file would apparently give a concavity to the work, the real tendency, however, especially on narrow work, is the reverse, (owing to the work acting as a fulcrum, over which the file moves with more or less of a rocking motion,) giving an actual convexity to its surface, except when in the hands of a skillful operator. The real aim, therefore, should be, to cause the file to depart only so much from a true right line, as will be necessary to feel that each inch of its stroke is brought into exact contact with the desired portion of the work.

The movements here referred to, have reference to those in which both hands are used *upon flat work*, requiring nicety and trueness of finish, and the difficulties to be overcome in producing even a comparatively true flat surface with a file, require much practice on the part of the operator.

In filing ovals and irregular forms, the movements, while not considered so difficult or trying, nevertheless require considerable experience, and a good eye, to so blend the strokes of the file upon the round or curved surfaces, as to give the best effect; the varied nature of the work upon this class of surfaces, though much might be said, prevents any detailed definition as to the movements of the file, within the limit of this article.

In point of economy, the pressure on the file should be relieved during the back stroke; this will be apparent to any one who will examine the formation of the points of the teeth, (see illustrations in **Figs. F and G**, pages 51 and 52,) when it will be seen that the file can only *cut* during the ordinary or advancing stroke, and that equal pressure during the back stroke must be very damaging to the points of the teeth.

**DRAWFILING.**—Files are sometimes used by grasping at each end, and moving them sidewise across the work, after the manner of using the spoke-shave. This operation is known as *drawfiling*, and is usually performed in laying the strokes of turned work, lengthwise, instead of circular, as left from the lathe finish, as well as when giving a final fit to the shaft that is to receive a coupling; cases, generally, in which no considerable amount of stock is to be removed, thus, any defects in the principle of construction, or arrangement, of the teeth of the file, are not so readily apparent.

Files, as they are ordinarily made, are intended to cut when used with a *forward* stroke, and the same file cannot work smooth, or to the best advantage, when moved sidewise, unless care is taken that the face of the teeth present themselves, during the forward movement of the file, at a sufficient angle to *cut*, instead of scratching the work. To accomplish this, the angle at which the file is held, with respect to the line of its movement, must vary, with different files, depending upon the angle at which the *last*, or *up cut* is made. The pressure should also be relieved during the back stroke, as in ordinary filing.

When properly used, work may be finished somewhat finer, and the scratches more closely congregated, than in the ordinary use of the same file; as, in drawfiling, the teeth produce a shearing or shaving cut.

**FIRST USE OF A FILE.**—In economizing the wear of files intended for general purposes, consideration should be given to the kind of material which they may be subjected to, in the different stages of their use.

In the ordinary use of the machine shop, the first wear of these files should be in finishing the larger surfaces of cast iron, bronze, or brass metals, all of which require a keen cutting tooth; they may then be made to do good execution upon the narrower surfaces of these metals, also upon wrought iron and soft steel; although to obtain the best results, the file suited for general purposes is not so well adapted to filing brass, or other similar soft metals, as those whose teeth are arranged for this purpose.

**PREPARING WORK.**—The corners or thin edges of iron castings are very likely to become chilled, and a thin scale or skin produced over the entire surface of the casting, caused by the hot metal coming in contact with the moist sand of the foundry moulds; this outer skin is usually much harder than the metal beneath it, and many times, the thin edges or corners are chilled so as to be harder even than the file itself.

The necessity, therefore, of removing this scale and chilled surface, becomes readily apparent, and all mechanics who give any consideration to the proper and economical use of the file, will be careful to see that the scale and sand are first removed by pickling, and the surfaces which have become chilled by grinding, before applying the file.

**PICKLING THE WORK.**—The pickle for gray iron castings is generally made by mixing sulphuric acid and water, in the proportion of two or more parts of water to one of acid, and is usually kept for this purpose, in a trough lined with lead.

The articles to be pickled are sometimes immersed in this bath, where they are allowed to remain for a short time; they are then removed, and the acid is allowed to act upon their surfaces until the scale has loosened, when they are washed off with water. More often, however, the pickle is dipped from the trough, and poured over the castings, which are placed on a sloping platform, (thus allowing the acid to return to the trough,) where, after remaining for a sufficient time, they are then washed. When dry, the castings are either rattled, or scraped and cleaned with old files and wire scratch-brushes, until the surface is freed from scale and sand.

To pickle brass, or gun-metal castings, a mixture of nitric acid and water may be used, in the proportion of, say one part acid to five of water; the treatment being the same as that of the iron castings. While not in general use upon the coarser kinds of brass work, the pickle is desirable for smaller castings, or those requiring to be protected with lacquer.

**WHEN OIL SHOULD NOT BE USED.**—All files, when they leave the manufactory, are covered with oil to prevent them from rusting. While this is not objectionable for many uses to which the file is put, there are cases where the oil should be thoroughly removed, as when the file is to be used in finishing the larger cast iron surfaces, which are of a glassy nature; the principal difficulty being, to make the file “bite,” or keep sufficiently under the surface to prevent glazing; otherwise, the action not only hardens or burnishes the surface operated upon, but dulls the extreme points of the teeth, thus working against the desired end in both directions.

**WHEN OIL MAY BE USED.**—Oil may, however, be used to good advantage on new files, which are put immediately to work upon narrow fibrous metals of a harder nature; in such cases, it is not uncommon, with good workmen, to fill the teeth with oil and chalk.

Oil is also useful on fine files, in the finishing of wrought iron, or steel, as, by its use, the teeth will not penetrate to the same degree, and the disposition to “pin,” and scratch the work, is materially less than when used dry.

**CLEANING THE FILE.**—The dust or small particles removed from the material operated upon, are always more or less liable to clog and fill the teeth; this tendency is especially aggravated when the file is used upon wood, horn, and such other materials, as, upon being mixed with the oil in the teeth, become baked, when dry, and thus prevent the teeth from penetrating the work, to say nothing of the appearance of being worn, or the tendency to injury from rust.

It therefore becomes necessary that the file should be cleaned, not only at intervals during its use, but carefully, before being laid aside, if the best results are to be attained.

This cleaning is done in several ways; sometimes, in the finer files, by rubbing the hand over them, or by drawing them across the apron of the workman; at others, by striking their edge upon the

bench or vise, and again, (which is a more common method upon the larger files,) by the use of a strip of old or worn out card clothing, tacked to a piece of wood, having a handle shape at one end—a device which is usually rudely constructed by the operator.

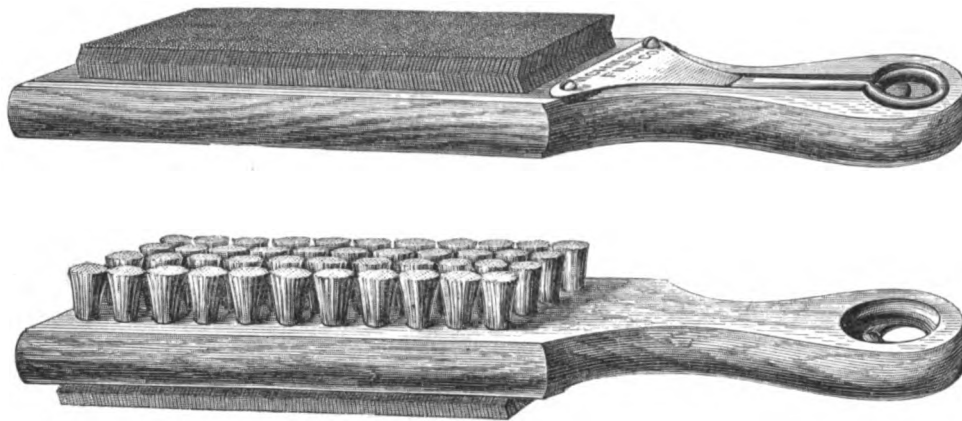

The File Card and File Brush, illustrated above, (a description of which is given on page 38,) will be found excellent tools, and master mechanics should see that every person in their employ using a file, is furnished with one or the other of them, and insist that they be used, if he deems it desirable to economize in the wear of his files.

In removing oil from the teeth of a new file, a ready way is, to rub chalk or charcoal across the teeth, and brush thoroughly. By repeating the operation a few times, the oil will be entirely absorbed, and the file will be in its best possible condition for use upon cast iron.

When the teeth of files are clogged with wood, or other soft substance, which has become baked into them, if held in boiling hot water for a few moments, the imbedded substance becomes so loosened, that it may easily be carded out of the teeth. If the operation be quickly performed, any moisture remaining will be readily evaporated by the heat retained in the file.

**CARE IN PUTTING AWAY.**—One of the most destructive customs among a large number of mechanics of the present day, is that of loosely throwing their files, fine and coarse, small and large, into a drawer filled with cold chisels, hammers, turning tools, &c., and then throwing the chisels, hammers and other tools onto the files.

Now when we consider the small portion of the points of the teeth which is worn off by use in an extreme wear, and that to effectually dull them for some kinds of work requires but the slightest rubbing upon a hard substance, it will be easily seen that the evils of this habit should be more carefully considered by the master mechanic, and suitable provision made to avoid its destructive tendencies.



## TERMS DEFINED.

**Back.**—A term commonly used to describe the convex side of half-rounds, cabinets, pitsaws and other files of similar cross-sectional shape.

**Bellied.**—A term sometimes used to describe a file having a fullness in the centre. See *full taper* and *equating*, under General Description, page 5.

**Filing Block.**—A piece of hard, close-grained wood, having grooves of varying sizes upon one or more of its sides. It is usually attached to the work bench by a small chain, and when grasped in the jaws of a vise, is particularly useful in holding small rods, wires, or pins, which are to be filed; also in filing small flat pieces, which are held to the block by pins, or by letting in.

**Float.**—The coarser grades of single cut files are not unfrequently called *floats*, when cut for the plumber's use, or for use upon soft metals or wood. See *Single Cut*, page 6, and *Lead Float*, page 27.

**Hopped.**—A term known amongst the file makers, and used to represent a very coarse or *open* spacing of the teeth, (sometimes exceeding  $\frac{1}{2}$  inch,) mostly applied to the backs of half-rounds, and to the edges of quadrangular sections.

**Middle Cut.**—A term used to designate the cut of a file when it is of a grade of coarseness between the *rough* and *bastard*. It is but little used in this country.

**Re-Cut or Re-Cutting.**—The working over of old or worn out files, by the several processes of annealing, grinding out the old teeth, re-cutting, hardening, etc., and thus again preparing them for use.

This operation is sometimes repeated two and even three times, but the economy of re-cutting at all, is very much questioned in some of the best appointed shops of the present day.

**Safe Edge (or Side).**—Terms used to denote that a file has one or more of its edges or sides smooth or uncut, that it may be presented to the work without injury to that portion which does not require to be filed.

**Scraping** (see **Scrapers**).—As applied in machine shops, the process consists of removing an exceedingly small portion of the wearing surfaces of machinery by means of scrapers, in order to bring these surfaces to a precision and nicety of finish (as determined by the straight edge or surface plate) not attainable by the file, or by any other means with which we are acquainted.

Whitworth says, 'A mistaken idea prevails that scraping is a dilatory process, and this prejudice may tend to discourage its introduction. It will be found, however, to involve the sacrifice of less time than is now wasted on grinding; were the fact otherwise, it would be no argument against the preference due to the former. But it is worthy of observation that, in this instance, as

in many others, improvement is combined with economy. There is not only an incalculable saving effected by the improved surface, in its various applications, but there is also a positive gain of time in the preparatory process.

"When grinding was first discontinued in the establishment of Messrs. Whitworth & Co., no mechanic could be induced to take the work on the same terms as before, owing to the supposed extra labor of scraping. But experience has entirely removed this prejudice, and the work is now done with greater despatch.

"It is plain that, in machines intended to be used in reproducing other machines, errors in surface are of the utmost consequence, for the original defects are propagated in an aggravated form."

**Set.**—To file off or blunt the sharp edges or corners of file blanks, before and after the first or *over cut* is made, in order to prevent weakness of the teeth, and consequent liability to break when put to use.

**Steel.**—A round rod of hardened steel, having either circular, diagonal, or longitudinal striated lines, and used for sharpening knives.

Dr. Young, in his "Labor in Europe and America," quotes from a recent article by Mr. Chas. Vincent, as follows:

"In the sepulchres of Thebes may be found delineations of butchers sharpening their knives on round bars of iron attached to their aprons. The blades of the knives are painted blue, which fact proves that they were made of steel, for in the tomb of Rameses III. this color is used to indicate steel, bronze being represented by red. An English gentleman has recently discovered near the wells of Moses, by the Red Sea, the remains of iron works so vast that they must have employed thousands of workmen. Near the works are to be found the ruins of a temple and a barrack for the soldiers protecting or keeping in order the workmen. The works are supposed to be at least 3000 years old."

**Superfine (or Super) Cut.**—A term applied by the Lancashire file makers to designate a grade of cut called by us *Dead Smooth*.

**Surface Plate or Planometer.**—Consists of a close grained and hard cast iron plate, usually strengthened by three principal ribs, and supported upon three feet or bearing points; having one or more of its faces made as smooth and as true as can possibly be done.

They are used as trial plates for testing and correcting other surfaces.

**Taper.**—Both single and double cut hand-saw taper files are very commonly known as *taper single cut* or *taper double cut*. See pages 19 and 20; see also page 8, illustrating some of the abbreviations often used.

The term is generally used to define the *shape* of the file only. See *Kind*, pages 4 and 5.



# INTERNATIONAL EXHIBITION.

PHILADELPHIA, 1876.



THE United States Centennial Commission has examined the report of the Judges, and accepted the following reasons, and decreed an award in conformity therewith.

PHILADELPHIA, May 4th, 1877.

## REPORT ON AWARDS.

Product, *Files and Rasps* \_\_\_\_\_

Name and Address of Exhibitor, *Nicholson File Company* \_\_\_\_\_  
*Providence, Rhode Island* \_\_\_\_\_

The undersigned, having examined the product herein described, respectfully recommends the same to the United States Centennial Commission for Award, for the following reasons, viz.:

*Being exceedingly well cut and of excellent material* \_\_\_\_\_

\_\_\_\_\_ *Daniel Steinmetz, of Pha.*

*Signature of the Judge.*

### APPROVAL OF GROUP JUDGES.

- J. D. Emboden, of Richmond, Va.*
- Chas. Staples, Jr., " Portland, Me.*
- E. L. Beed, " Clearfield, Pa.*
- J. Diefenbach, " Germany.*
- David McHardy, " Great Britain.*

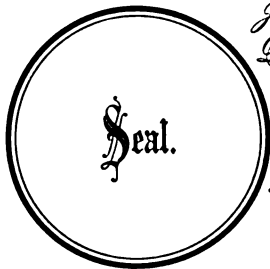

A true Copy of the record.

*Francis A. Walker,*

*Chief of the Bureau of Awards.*

Given by authority of the United States Centennial Commission.

*A. T. Coshorn,*

*Director General.*

*J. L. Campbell,*

*Secretary.*

*J. E. Haruley,*

*President.*

# NICHOLSON FILE CO.

SOLE MANUFACTURERS OF

## FILES AND RASPS

HAVING THE INCREMENT CUT.

ALSO,

## FILERS' TOOLS & SPECIALTIES.

---

“Nicholson File Co.’s” Files and Rasps,  
“Double Ender” Sawfiles,  
“Slim” Sawfiles,  
“Racer” Horse Rasps,  
Handled Riffers,  
Machinists’ Scrapers,  
File Brushes, File Cards,  
Surface File Holders,  
Vise File Holders,  
Stub Files and Holder,  
Improved Butchers’ Steels.

---

**MANUFACTORY & OFFICES AT PROVIDENCE, R. I., U. S. A.**

EXECUTIVE OFFICERS.

W. T. NICHOLSON, Pres’t.    GEO. NICHOLSON, Treas.

---

B. F. THURSTON, Attorney and Counsellor.

*Incorporated 1864.*

*Capital Stock, \$400,000.*

# CAUTION!

We desire to call the attention of our friends and the public, to a dangerous and most injurious means of deception, which we have found practiced, at different times, during the past few years.



We refer to *old* or worn out files of our make, which have been *treated* by immersing them in an *acid bath*, and afterwards selling them in packages bearing a label of similar appearance to ours, having the words "Nicholson" or "Nicholson Files," "Increment Cut," &c., printed thereon; thus palming the same off as our original goods.

As this *fraud* is of a most dangerous character, we advise caution against it—as files, so "doctored," are comparatively valueless for use.

We warn all parties that if detected in this, or any "doctoring" of our files, with the intention of trading upon our hard earned reputation, they will be presented to the courts for treatment.

All original packages of *First Quality* Files leaving our Works, bear a **Green Label**, a copy of which is herewith attached, showing the largest of the three sizes used.





Eng 1738.78  
A treatise on files and rasps descr  
Cabot Science 006172558



3 2044 091 846 816